

Raspberry Pi Enabled Microwave Test Equipment

Dave G8GKQ



Topics

- The Hardware
- ATV Capabilities
- Voice/CW Capabilities
- Test Equipment
- Web Control/view





Test Equipment

- Signal Generator
- XY Display
- Band Viewer
- Power Meter
- Noise Figure Indication
- Frequency Sweeper
- DMM Display/logger

The logo for BATC, featuring the letters 'BATC' in white on a black rectangular background, which is tilted and surrounded by blue circular motion lines.

BATC

Portsdown 4 Hardware

7 inch Touchscreen

Raspberry Pi 4

Portsdown 4 Hardware

BATC

BATC Portsdown 4 DATV System Main Menu

TX		RX	M2	M3
Modulation	Encoder	Output to	Format	Source
32QPSK	H264	Lime Mini	4:3	PI Cam
Freq	Sym Rate	FEC	Band/Tvtr	Lime Gain
437 MHz	333	2/3	70_cm	88
EasyCap	Caption	Audio	Atten	Att Level
Comp Vid	On	Auto	NONE	-10.00
Preset 1	Preset 2	Preset 3	Preset 4	Store
146.5_333	437_1MS	1255_HD	437-Ugly	Preset

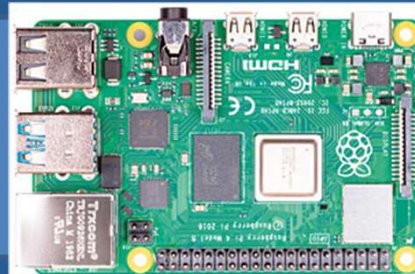



ATV Capabilities

- RPi 3 or 4 and Touchscreen with SDR
- DVB-S/S2 and DVB-T Transmitter
- DVB-S/S2 and DVB-T Receiver
- Video Stream Transmitter and Receiver
- Uses LimeSDR, Pluto or DATV Express



Example Builds





Voice/CW Capabilities

- RPi 4 and Touchscreen with Pluto or LimeSDR
- Langstone Microwave Transceiver by G4EML – 70 MHz to 6 GHz
- Needs Compatible USB Sound Dongle
- Optional Mouse-based Tuning Control

Langstone Interface

BATC

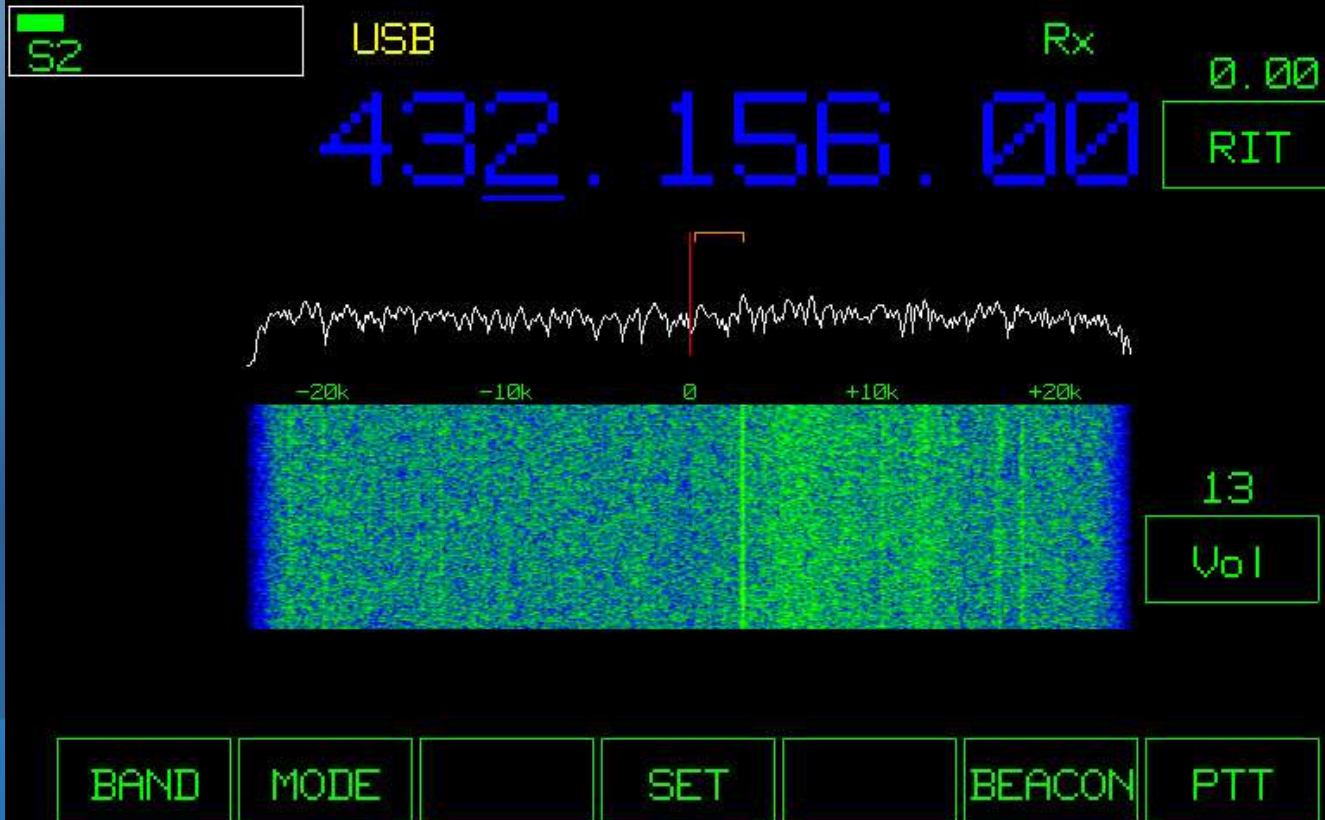

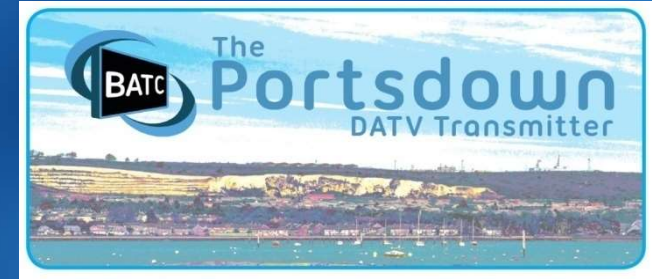

(Microwave) Test Equipment



Signal Generator

- Simple Interface to Multiple Sources
- Approximate Amplitude Calibration using Look-up tables
- Some sources not clean
- Covers 1 Hz to 30 GHz



Signal Generator

- Sources

- Pluto SDR - 6 GHz
- Pluto SDR x5 - 30 GHz
- LimeSDR Mini - 3.5 GHz
- ADF4351 - 4.4 GHz
- ADF5355 - 13.6 GHz
- AD9850 - 1 Hz to 50 MHz

- Elcom Source



- Nort SLO



BATC

Sig Gen Control

Portsdwn Signal Generator Control Panel

Lime Mini

OFF

Cal Lime

Exit

ON

1,255.000,000

+ 1.5 dBm

Save

Recall

Lime Gain = 77

BATC

LF Signal Generator

- AD9850 DDS Covers 1 Hz – 50 MHz

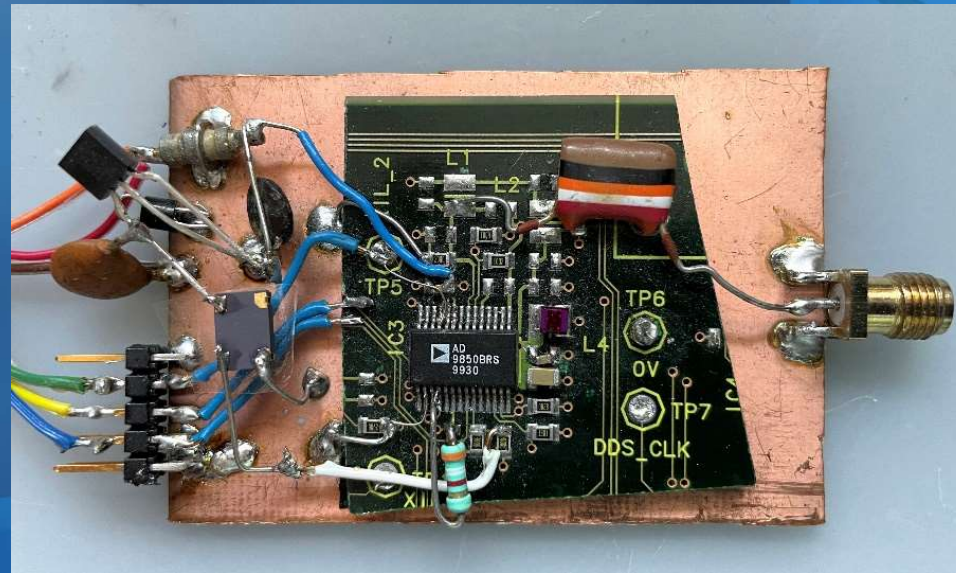



BATC

XY Display

- For use with HP141T or HP8559
- Portsdown with added 2 IC interface
- Provides
 - 500 x 400 pixel image
 - Screen Capture and Freeze
 - Normalisation

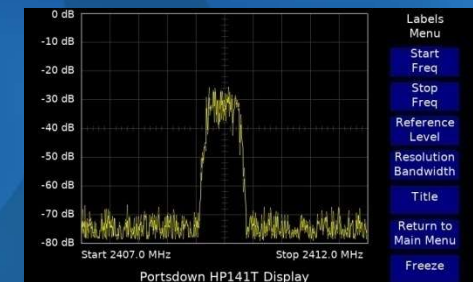

XY Display – How?

BATC

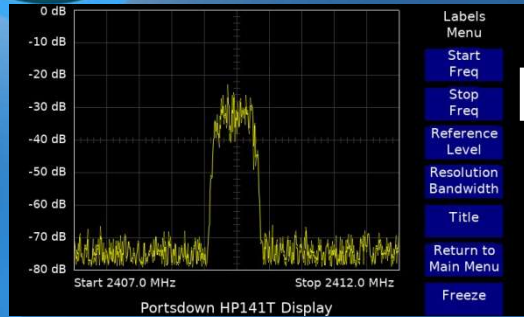

Display Ribbon Cable

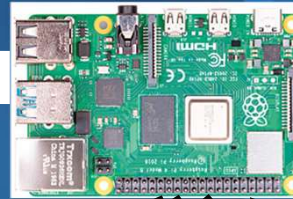

spi Data



Y input
Interface
X input

BATC

Typical Plot

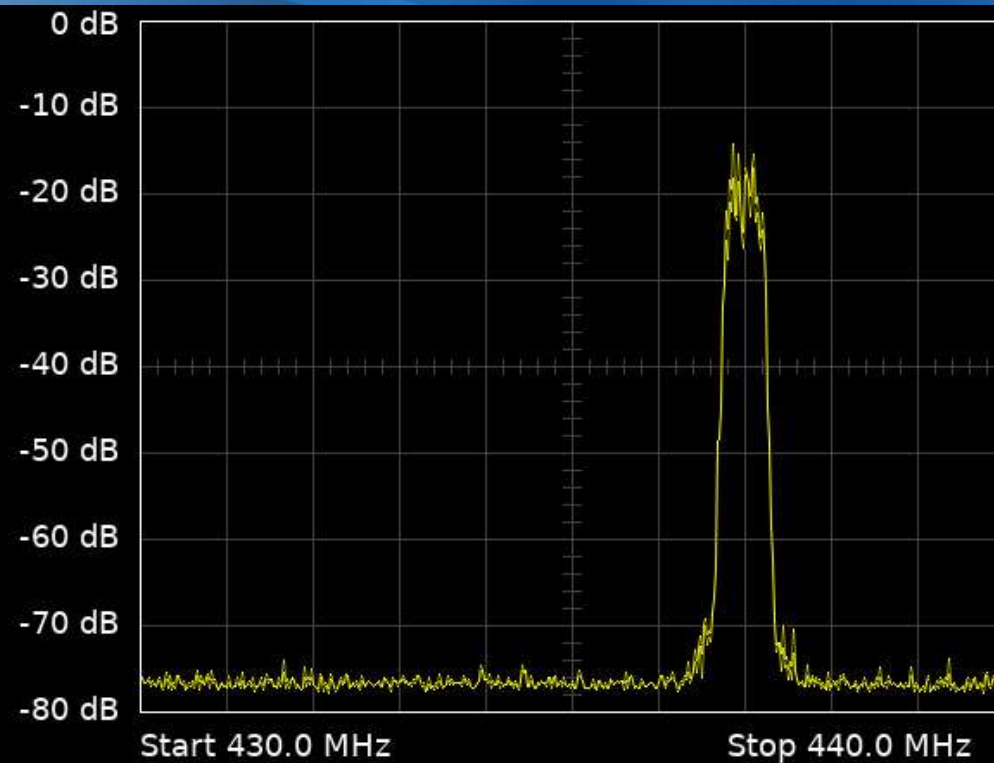

Labels
Menu

Start
Freq

Stop
Freq

Reference
Level

Resolution
Bandwidth

Title

Return to
Main Menu

Freeze

Portsdown HP8559A Display

BATC

XY Interface Circuit

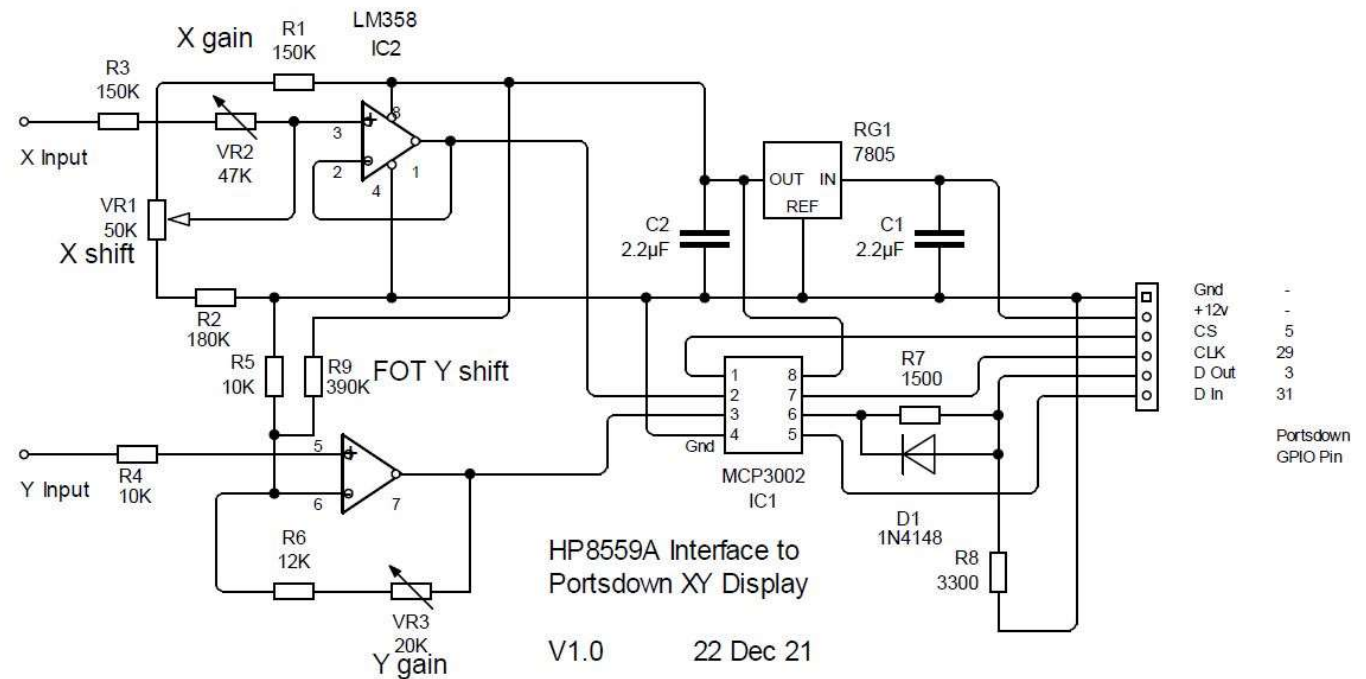



Band Viewer

- Portsdown 2020 and Portsdown 4
- LimeSDR, Airspy R2 and RTL-SDR
- Pluto on Portsdown 4 (with x5 mode)
- Intended as a “Panadapter”
- Accurate relative levels
- Dynamic Range Limited by SDR

Weak Signal Work

BATC

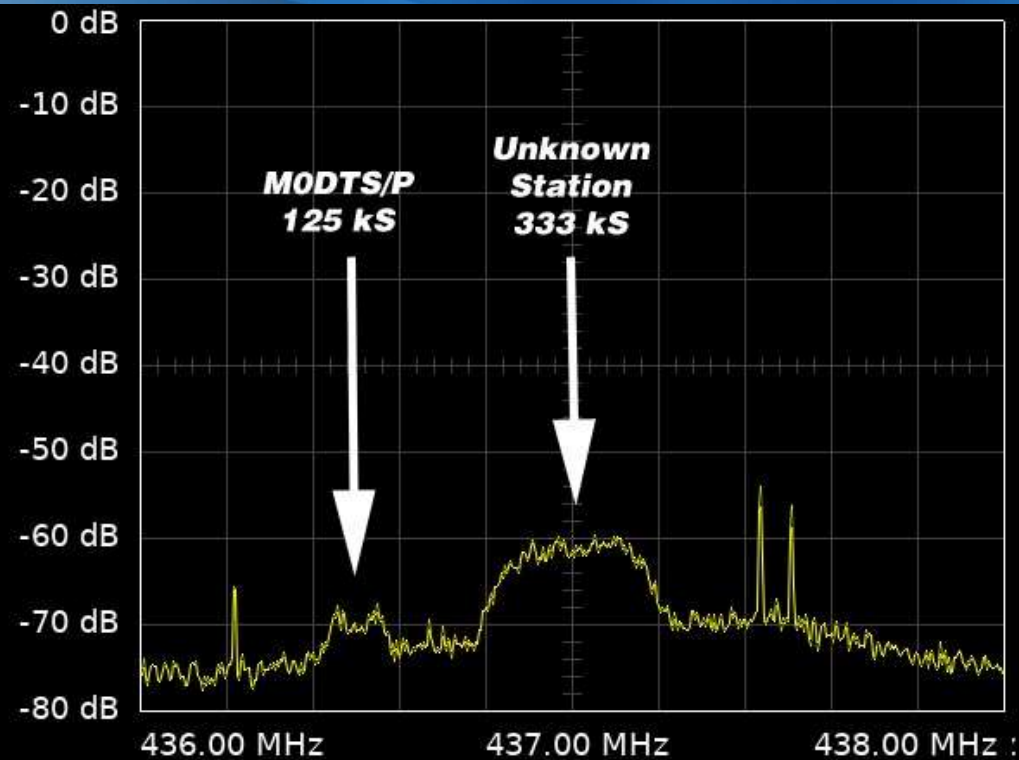

Gain Menu

100%

90%

70%

50%

30%

Back to Settings

Freeze

Portsdown Band Viewer

DATV Weak-signal Use

BATC

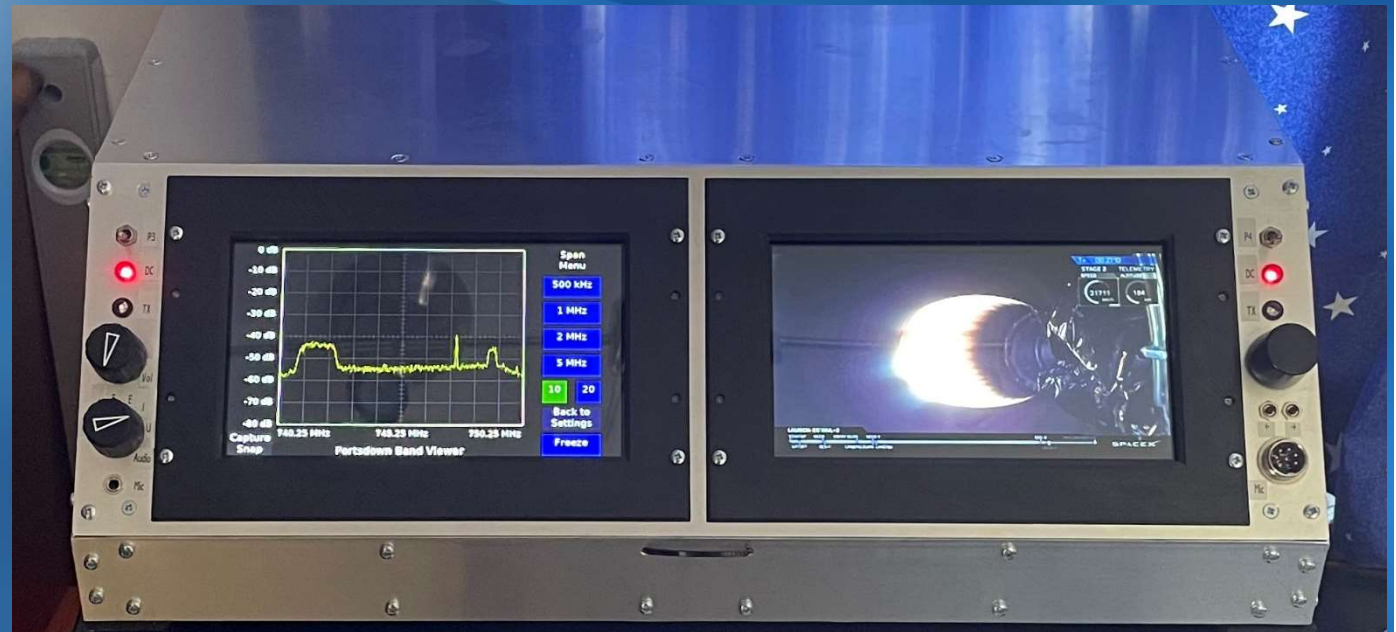

BATC

Peak Hold

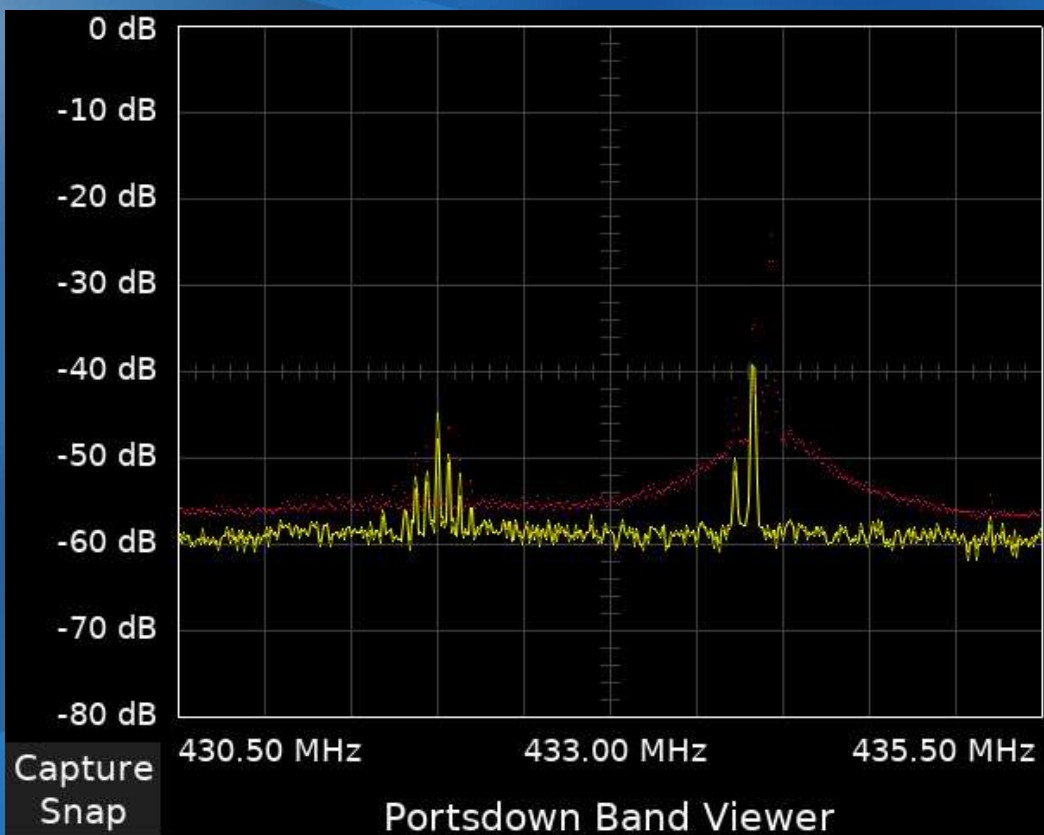

Marker
Menu

Peak

Peak
Hold

Manual

<-

->

Markers
Off

Return to
Main Menu

Freeze

BATC

Pluto 50 MHz Span

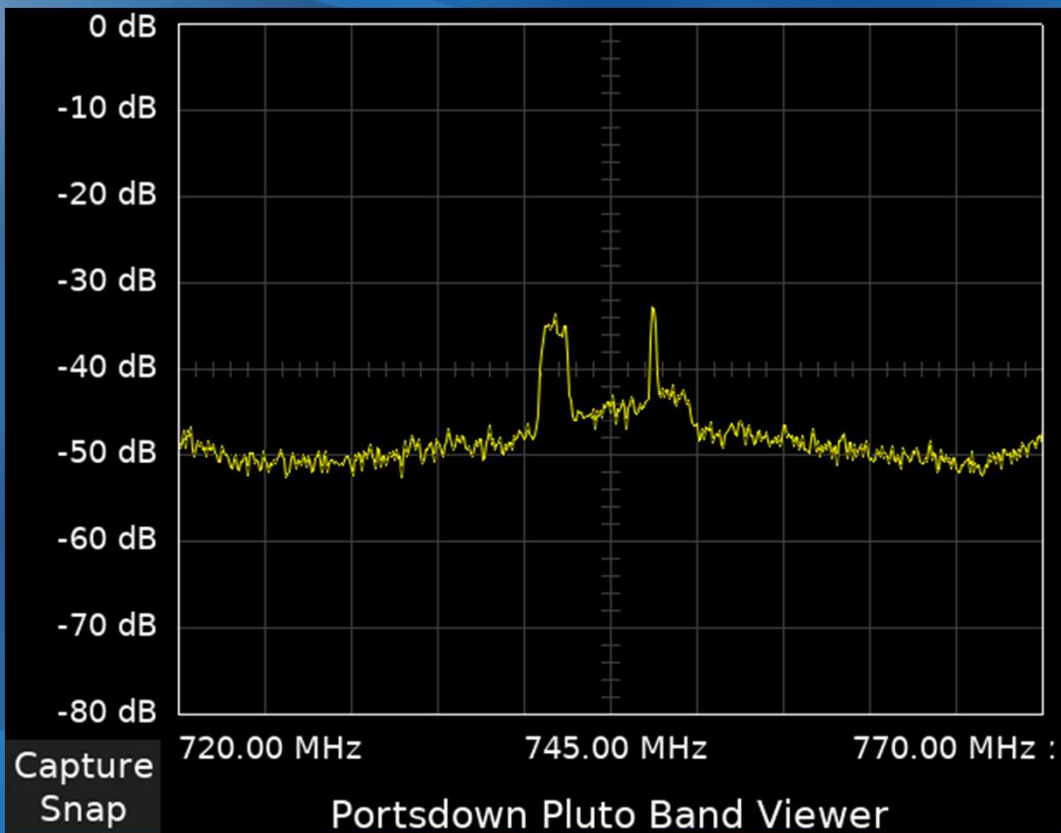

Span
Menu

2 MHz

5 MHz

10 MHz

20

50

Back to
Settings

Freeze

BATC

Power Meter

- Needs external sensor
- AD8318
- MCP3002 A-D
- More sensors in future

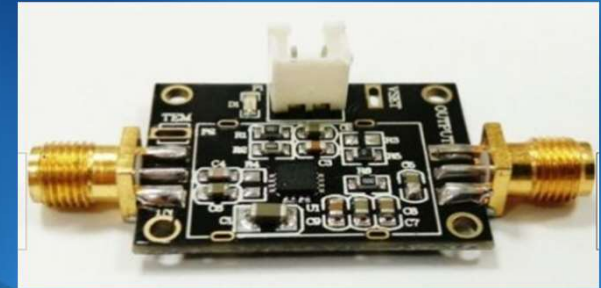

Power Meter Circuit

BATC

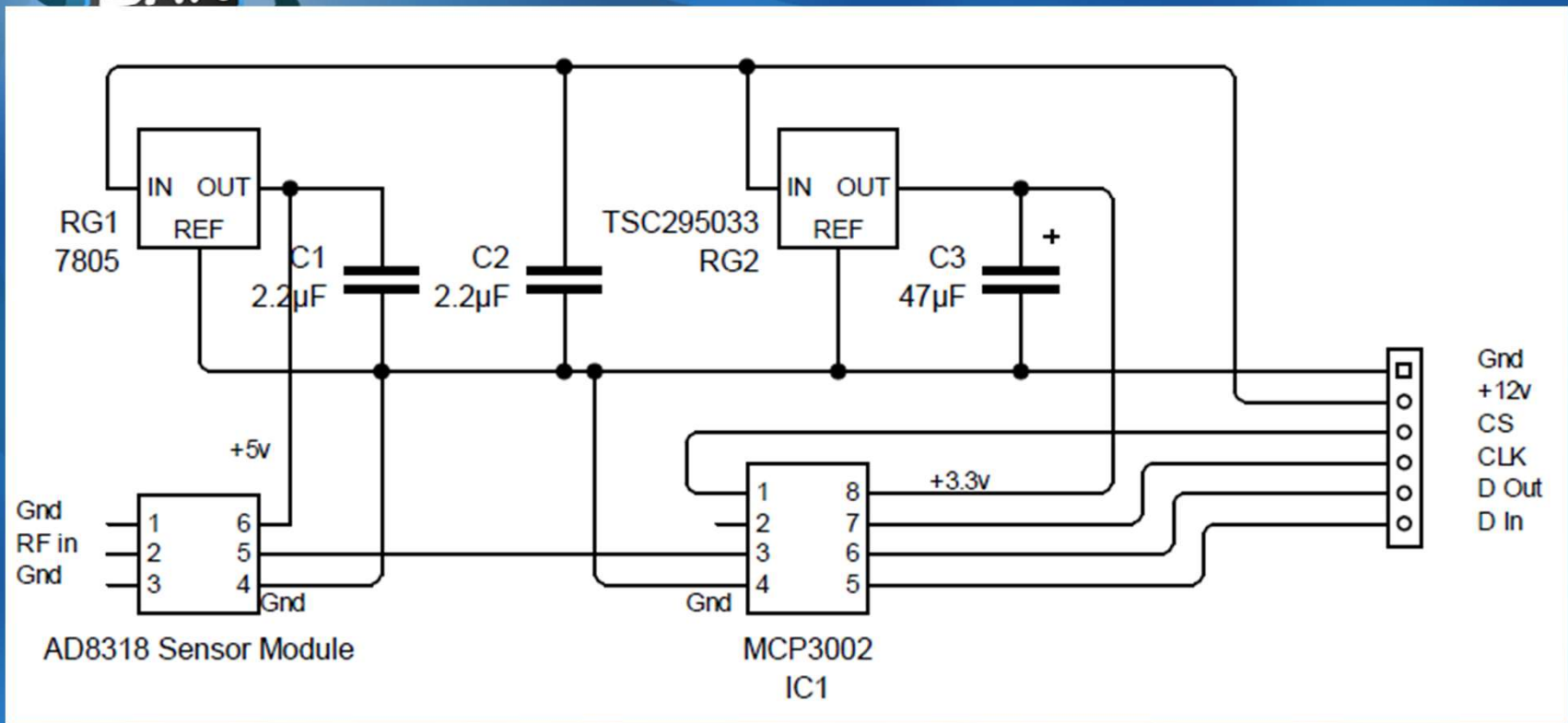

BATC

Meter Face



Sensor: ad8318-3

Portdown Power Meter

Main Menu

Settings

dBm

Mode

<-

->

System

Exit to
Portdown

Freeze



Power Meter Features

- Needle has “inertia”
- Selectable Ranges - dBm or mW
- Look-up table for linearity
- Calibration Factors can be entered
- Direct reading with attenuators
- An alignment tool – not an HP432!



The logo for BATC, featuring the letters 'BATC' in white on a black rectangular background, which is set against a blue circular graphic element.

BATC

Noise Figure Indication

- Use a Noise Source switched at ~ 4 Hz
- Measure Average Noise Power On & Off
- Calculate Noise Figure
- After calibration, calculate gain



NF Measurement – How?

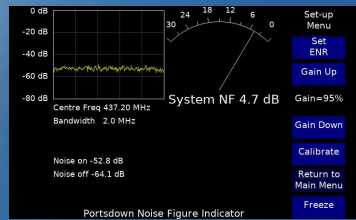

Display Ribbon Cable

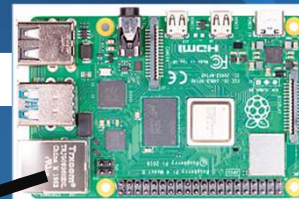

USB Cable

3v3 Switching Signal



Switched PSU

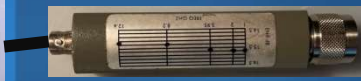

Noise Source



Device Under Test



LimeSDR Mini

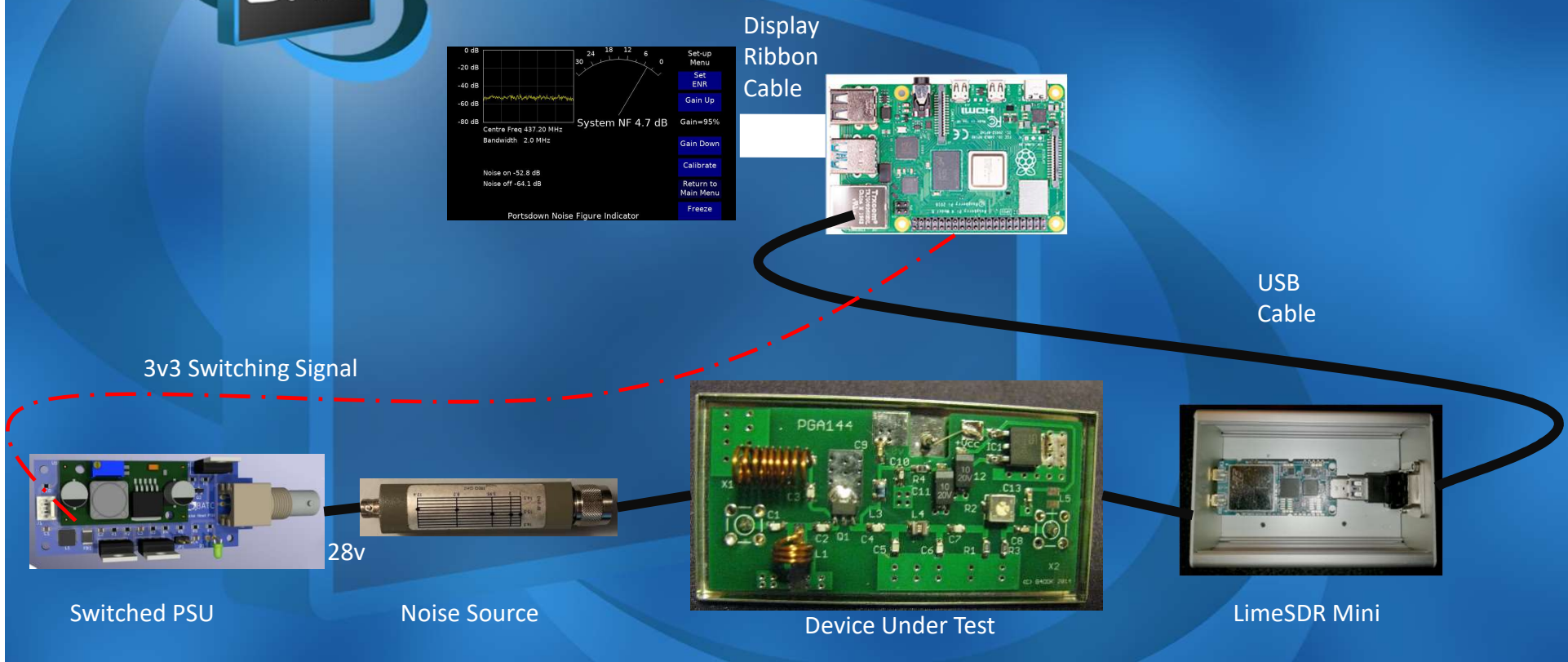

The logo for BATC, consisting of the letters 'BATC' in white on a black rectangular background, which is tilted and surrounded by blue curved lines.

BATC

Noise Figure Notes

- LimeSDR must be operating in linear region
- No significant signals in bandwidth
- Bandwidth?
- Minimise digital noise locally

Noise Source



BATC



- Calibrated Noise Sources are rare
- RF Design BBGen (ENR 24 dB 5 GHz) £84
add External Attenuator ?
- RF Design RXGen (ENR 10 dB 2.4 GHz)
Available from G3AAF (£60 BATC Members)
- Homebrew?



The logo consists of the letters "BATC" in white, bold, sans-serif font, centered on a black trapezoidal background. This background is set against a blue circular graphic that resembles a stylized signal or a lens flare.

BATC

Noise Source Switching PSU



- Commercial sources need 28v
- RF Design Sources need 12v or 13.5v
- Needs to be a clean supply
- BATC design (and PCB) available

BATC

Noise Figure Application



Centre Freq 437.20 MHz
Bandwidth 2.0 MHz

Noise on -52.8 dB
Noise off -64.1 dB

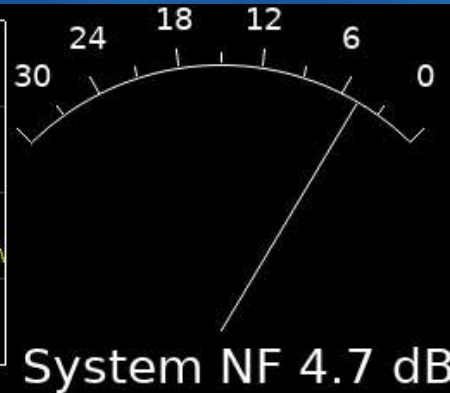

Set-up
Menu

Set
ENR

Gain Up

Gain=95%

Gain Down

Calibrate

Return to
Main Menu

Freeze

Portsdown Noise Figure Indicator

BATC

Calibration

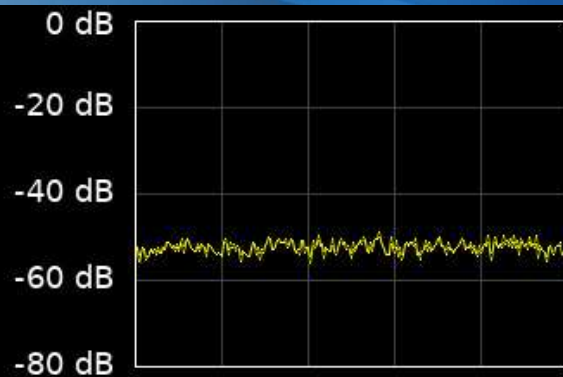

Centre Freq 437.20 MHz
Bandwidth 2.0 MHz

Noise on -52.8 dB
Noise off -64.1 dB

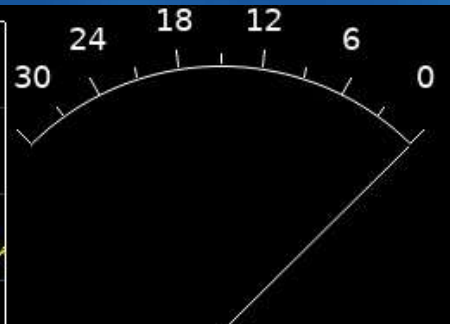

Device NF -0.1 dB
Device gain -0.0 dB

Set-up
Menu

Set
Input ENR

Gain Up

Gain=95%

Gain Down

Calibrated

Return to
Main Menu

Freeze

Portsdown Noise Figure Indicator

BATC

Device Gain and NF



Centre Freq 437.20 MHz
Bandwidth 2.0 MHz

Noise on -29.8 dB
Noise off -44.9 dB



Device NF 0.8 dB

Device gain 23.2 dB

Set-up
Menu

Set
Input ENR

Gain Up

Gain=95%

Gain Down

Calibrated

Return to
Main Menu

Freeze

Portdown Noise Figure Indicator

The logo for BATC, featuring the letters 'BATC' in white on a black rectangular background, which is tilted and surrounded by blue curved lines.

BATC

Noise Figure Notes

- Not an exact science
- Beware LimeSDR Digital Noise
- Use attenuators for error-checking
- Beware changing source VSWR between noise on and noise off

The logo for BATC, featuring the letters 'BATC' in white on a dark blue rectangular background, which is partially enclosed by a blue circular swoosh.

BATC

RF Sweeper

- Combine the Signal Generator with the Power Meter
- Add some automation
- Frequency Response Sweeper

Sweeper - How?

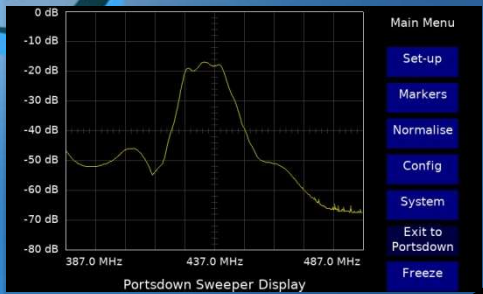

Display Ribbon Cable

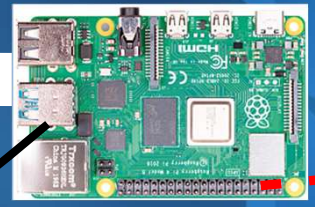

USB Cable

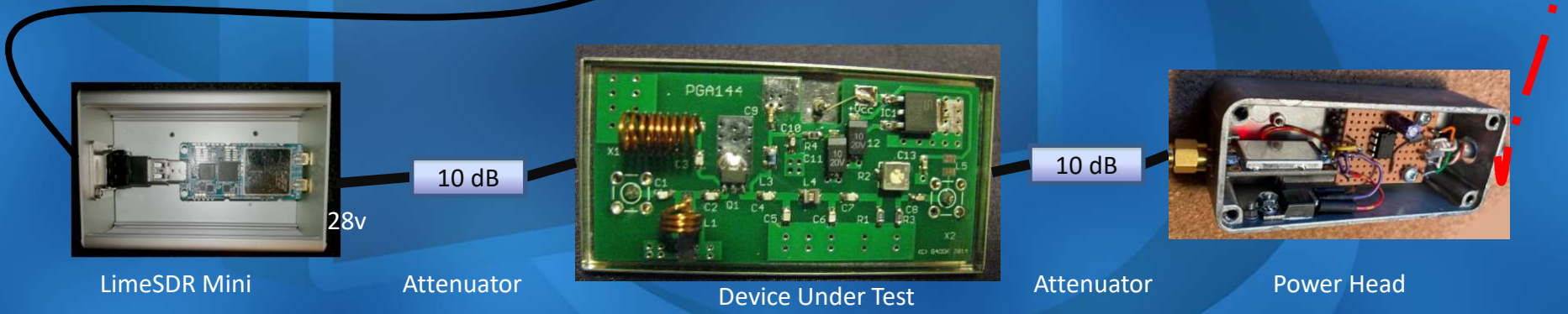

BATC

Checking a Filter

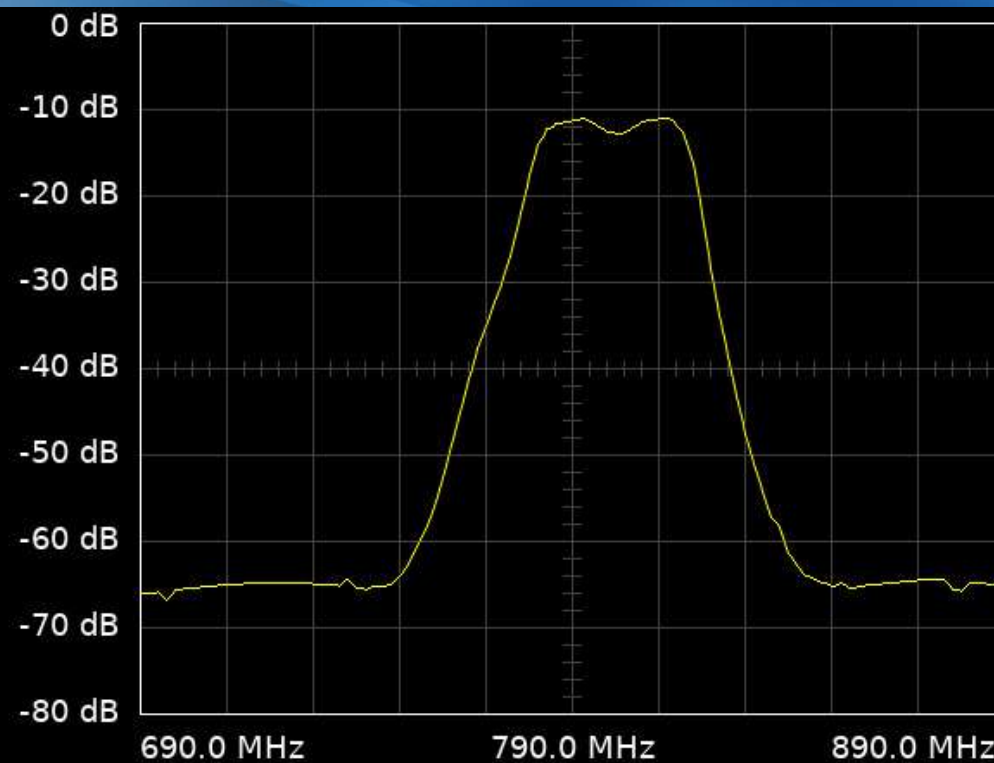

Portsdown Sweeper Display

Main Menu

Set-up

Markers

Normalised

Config

System

Exit to
Portsdown

Freeze

Sweeper Limitations

The logo for BATC, consisting of the letters 'BATC' in white on a dark blue rectangular background, which is itself set within a larger, stylized blue circular graphic element.

BATC

- Slow scan speed – Reduce samples?
- Responds to Spuri from Source
 - LimeSDR 3rd Harmonic 15 dB down?
- LimeSDR source only at present

BATC

DMM Display

- Uses Parkside PDM300 Meter (£11.99 Lidl)
- Add an opto-isolator on serial output
- Only a display so far
- Logger under development



The logo for BATC, featuring the letters 'BATC' in white on a dark blue rectangular background, which is partially enclosed by a blue circular graphic element.

BATC

DMM Display

12.07

Capture
Snap

Main Menu

Settings

dBm

Mode

<-

->

System

Exit to
Portsdown

Freeze

The logo consists of the letters 'BATC' in white, bold, sans-serif font, centered on a dark blue, trapezoidal shape. This shape is surrounded by several concentric, glowing blue circles that create a sense of motion or a signal. The background of the entire interface is a dark blue gradient with abstract, glowing blue shapes that resemble a stylized 'P' or a signal tower.

BATC

Easy Wifi Connect

Select one of these WiFi Networks:

Page 1 of 1

- 1 TNSCAPE9C02B
- 2 PixienetG
- 3 DIRECT-8y-FireTV_7fd5
- 4 Hidden Network
- 5 PixienetG

Previous Page

Cancel

Select

Next Page

Web Control or view

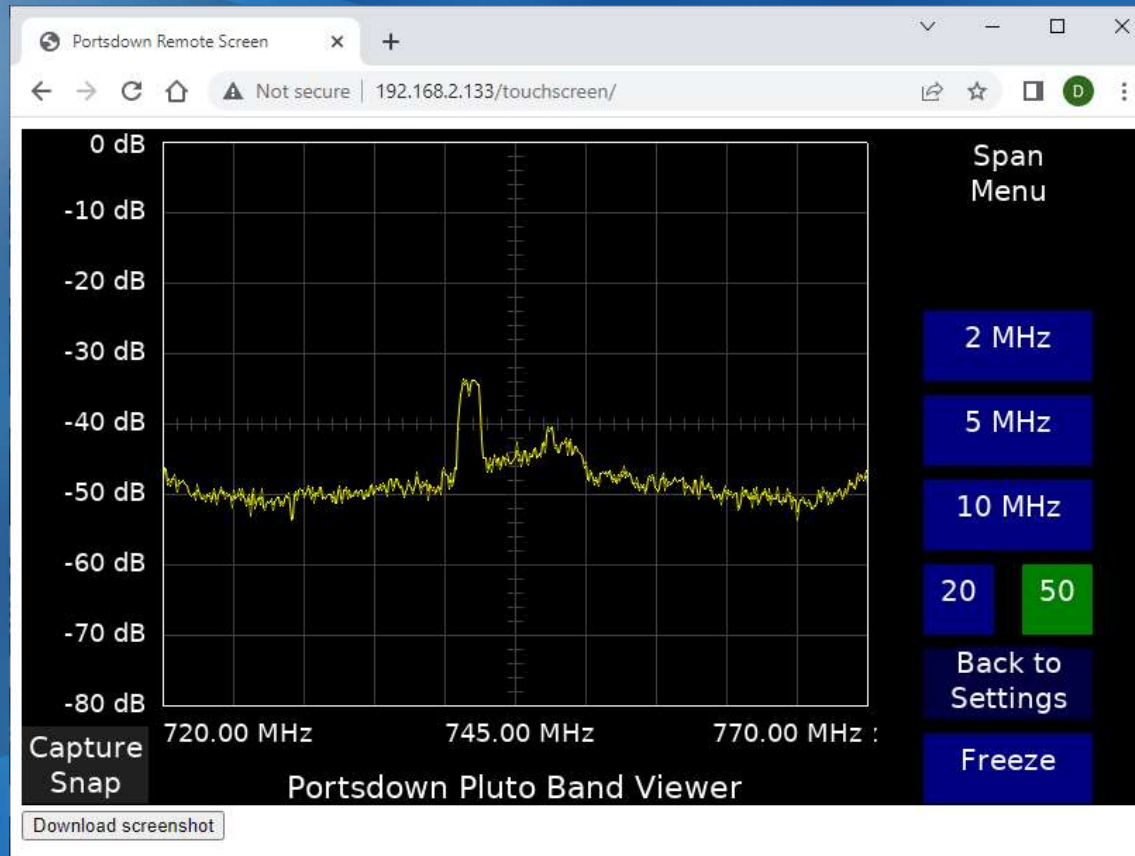

BATC

Portsdown Interface



- Single interface for spi Power, Serial and Data
- Defined in CQ-TV



Raspberry Pi Availability

- Due to improve in July 2023
- Raspberry Pi Shops
- Use rpilocator.com



rpilocator @rpilocator · Oct 17

Stock Alert (DE): RPi 4 Model B - 1GB RAM is In Stock at Welectron
rpilocator.com/?instock #PI4

- Do not buy from eBay!

Future Developments?

BATC

- Waterfall display for BandViewer
- Pluto NF Meter

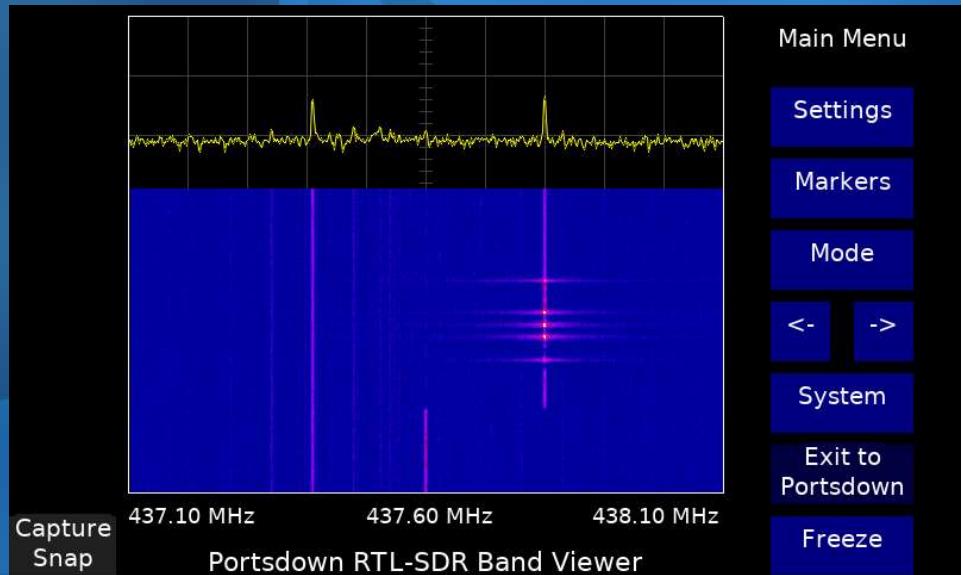



Summary

- Raspberry Pi, Touchscreen and peripherals provide a very capable platform for RF activities
- Peripherals **MUST** be the exact type – its not like Windows
- Open source (with one exception – DVB-T RX)
- BATC Wiki is primary information source
- Go and play with the applications and hardware



BATC

Questions