

RPCB 736
Replacement Front End Kit
Fitting Instructions
for FT 736R

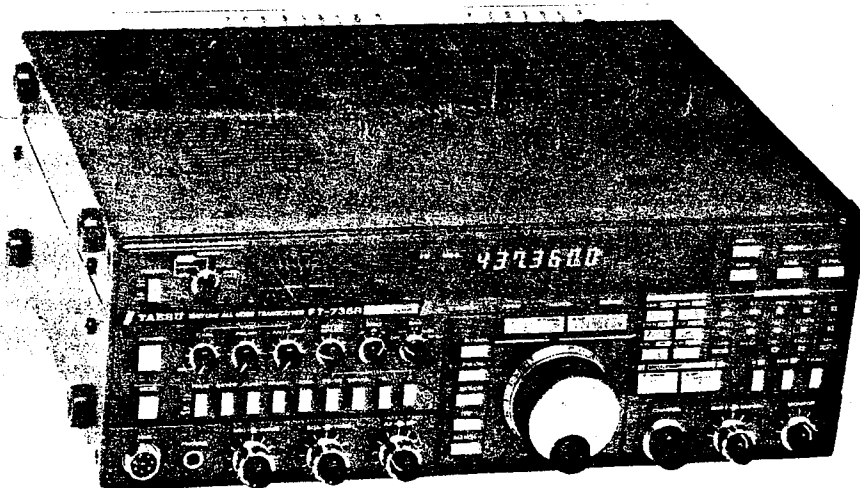

(c) 1993 muTek limited

Issue 1 02/02/1993
2 29/09/1993

muTek limited
P.O. Box 24
Long Eaton
Nottingham
NG10 4JA

Contents

- 1) Acknowledgement
- 2) Parts List
- 3) Specification
- 4) Circuit Description
- 5) Fitting Instructions
- 6) Circuit Diagrams
- 7) Parts Lists

Parts List

Your kit should contain the following parts, if any are missing please contact your supplier in the first instance.

- 1) RPCB 736_2_MN 2m main pcb
- 2) RPCB 736_70_MN 70 cms main pcb
- 3) RPCB 736_PA 2 2m PA pcb
- 4) RPCB 736_PA 70 70cms PA pcb
- 5) Fixings Kit consisting of:-
 - i) M3 tap
 - ii) 6 off M3 pillar
 - iii) IF interconnection cable
 - iv) N type chassis connector
 - v) 6 off M3 X 6 screws
 - vi) 13 off M3 X 5 taptite screws
 - vii) 1" length of silver plated wire
 - viii) 10uf 35V capacitor
 - ix) L.O. interconnection cables (2)

Note

If the kit has been fitted for you by an approved installer then all parts will have been fitted, and you should have the two old PA pcb's and the old 430MHz front end unit returned to you.

Specification

2m Section	Original Spec	muTek Spec
Noise figure	8 dB	< 2 dB
Selectivity +/- 12.5kcs	-3 dB	-25dB
+/- 15 kcs	-10dB	-60 dB
Image rejection	>60 dB	> 70 dB
Intermodulation free dynamic range	80 dB	> 90 dB
70 Cms Section	Original Spec	muTek Spec
Noise figure	18 dB	< 1.5 dB
Selectivity +/- 12.5kcs	-3 dB	-25dB
+/- 15 kcs	-10dB	-60 dB
Image rejection	>60 dB	> 70 dB
Intermodulation free dynamic range	70 dB	> 80 dB

The above figures are based on the published specification and on measurements made on the prototype units, the production units are not expected to differ greatly from this specification.

Circuit Descriptions

The principle of the modification is to totally replace the front end of the original receiver with a new low noise circuit with greater linearity. In order to do this it was necessary to investigate the losses in the original PA circuit boards. The result of this was that any modification would be wasted unless the PA boards were replaced as well! This aspect having been resolved, a set of four boards have been designed and tested, to bring true muTek performance to an otherwise excellent transceiver.

The FT 736 uses a common receive I.F. of 13.69 MHz for all of the units. The 70 cms receiver has an additional 1st IF of 47.43MHz. There are a succession of two pole filters of varying widths in the original receive chain. The result of this is that little filtering of adjacent channel signals take place before AGC is implemented. This together with low level mixers contribute to poor intermodulation performance and limited selectivity. The muTek replacement uses an 8 pole monolithic crystal filter and AGC amplifier which is common to both the 2m and 70 cms receivers, and which can also be used to improve the selectivity of any other modules that are fitted (more details on this later).

The design of the VHF and UHF PA boards are very similar, and in fact are built on identical substrates. The pin allocations of the 70 cms pa brick are different to those of the 2m brick, so it is essential to get these the right way round. Both of the designs emulate the PA protection and S meter drive of the original design. The filtering and Tx/RX switching functions have been redesigned using a 7 element low pass filter for harmonic rejection and the changeover is accomplished with an ultra fast low loss relay. This has reduced the loss in both the Transmit and Receive paths. The bias tap for phantom powering of masthead amplifiers has also been included, but component values have been selected for minimum loss.

The 2m main pcb is similar in design to many other muTek front ends, consisting of a low noise dual gate mosfet amplifier, a band pass helical filter, a diode ring mixer with a high level LO injection and low noise IF amplification circuits. In order to achieve the maximum linearity, the mixer has been properly terminated at all ports, and the LO drive power has been optimised. The L.O. signal is derived from the synthesizer on the original receiver. This signal is combined with a D.C. bias which is used to control the power to the new receiver. The output from the mixer is connected to one port of a four way diode switch. This enables the low noise IF amplifier, 8 pole filter and AGC amplifier to be used by all of the receiver sections. The power to the IF processing sections is controlled by a bias voltage that is also used to polarise the diode switch. This can be done because the IF and AGC functions are common to all of the receiver modules.

The 70 cms receiver board is a completely new design. This receiver is a double conversion system and utilises a diode ring mixer for each conversion. The front end utilises a very low noise mosfet followed by a three pole helical filter. This is followed by the first mixer. The L.O. signal for this mixer is buffered by a BFR96s. The IF output at 47MHz is filtered to remove image products. No attempt at adjacent channel filtering is done at this stage. The filter is followed by a low noise wide dynamic range amplifier. This buffers the IF signal before the second conversion. This is important as it prevents spurious mixing between the two local oscillator signals. The LO for the second mixer is also buffered. Like the LO for the 2m amplifier, this LO signal also has a DC bias that controls the 70cms receiver. The output from the second mixer is combined with a dc bias and then connected to the common IF processing circuit on the 2m board.

Although the original IF and AGC connections for the 70cms receiver are not utilised, they are connected to the new board to eliminate any noise injection to the IF by the old receiver.

Fitting the RPCB 736 to the FT 736R

The fitting of the new boards to the transceiver is an extensive operation and should be carried out by an experienced person. Although there is no tuning to be carried out, some of the soldering work is of a delicate nature, and expensive damage can be caused if mistakes are made. Having said this, if care is taken the job is straightforward.

READ the instructions all the way through BEFORE you begin!

- 1) Disconnect all cables from the rear of the transceiver ESPECIALLY the mains cable. Under NO circumstances attempt to work on the transceiver with power connected.
- 2) Referring to fig 1, remove the screws that secure the top and bottom covers of the transceiver. Remove the covers taking care not to strain the connection to the loud speaker, which should be unplugged from the RX unit pcb at the side of the transceiver. Store the covers where they will not be damaged.
- 3) Starting with the 2m original board remove the following connectors:-
 - ✓ i) J04 Tx output
 - ✓ ii) J05 PA control
 - ✓ iii) J01 Rx input

Continuing with the 70 cms original board remove:-

- iv) J10 Tx output
- v) J06 PA control

From the 430 MHz front end unit (this is the little can screwed to the back of the pa screen - see fig 2) remove:-

- vi) J02 1st L.O input
- vii) I.F. output

- 4) From the little PCB's soldered to the backs of the feedthroughs to the 2 and 70 PA units unsolder the blue and red wires, making note of where they connect.

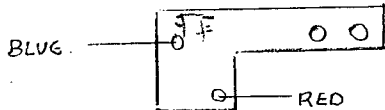

- 5) Disconnect the 13.8 Volt power feed to the PA units.
- 6) Disconnect the two black earth cables to the PA screen by removing one screw from the 2m board and one screw from the PA screen.
- 7) Remove the connectors from the two 9 Volt regulators mounted on the PA screen.
- 8) Remove the rear right hand screw from each of the 2 and 70 main unit boards, releasing the solder tag connected to the PA screen.
- 9) If extension units are fitted 'downstairs' in the FT 736, remove the 4 screws that secure each unit to the heatsink.
- 10) Remove the 3 screws '9' (see fig 3) that secure the power supply to the heatsink.
- 11) Remove the 3 long self tappers '1' (fig 3) that secure the heatsink to the rear of the chassis.
- 12) Remove the two short screws '2' (fig 3) that secure the connector panel to the heatsink. You should now be able to gently remove the heatsink from the transceiver by easing it out from behind the connector panel. Beware of the heatsink compound from the back of the power supply.
- 13) Place the Transceiver to one side for the next few operations. Lay the heatsink on its fins on the bench. Remove the 6 screws that secure the PA screen to the heatsink. Desolder the 5 control wires from each of the PA pcb's. Disconnect the RF input to the 430MHz front end unit (J01). Feed the coaxial cables through the screen, this should free the screen and 430 MHz front end unit from the heatsink.

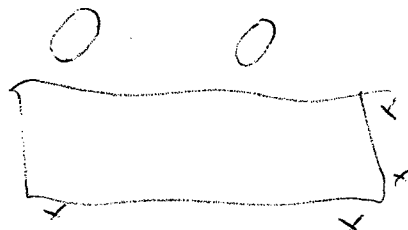
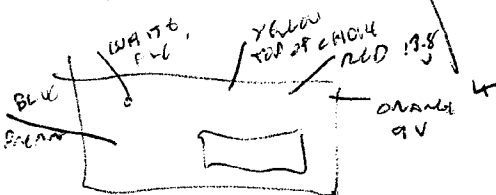

- 14) Remove the two screws that hold the 430 MHz front end unit to the screen. Carefully separate the two units and place on one side.
- 15) Return to the Heatsink and PA assembly. Carefully desolder the 5 wires from each PA Hybrid that connect it to the PA board. Also desolder the connection to the Antenna connector. Remove 5 screws that hold each PA board to the heatsink. Remove the old PA. pcb's and place on one side.
- 16) Clean the smudge of heatsink compound from the heatsink under the 70cms PA board.
- 17) Turn the heatsink over and remove the SO 239. From the kit supplied, extract the N type connector, the packet of M3 X 5 taptite screws and the two new PA boards. Secure the N type connector to the heatsink in place of the SO239, using 3 of the taptite screws. Turn the heatsink back onto its fins. Solder the short length of 18swg silver wire to the centre of each N type. Make sure that this is approximately vertical.
- 18) Identify the 2m and 70cms PA boards by the circle round the 2 or 70 in the bottom left hand corner. Using 5 taptite screws for each board, secure to the heatsink in the appropriate position, making sure that the wire from the N type connector passes through the board. *is coll wire!*
- 19) Carefully shorten the wires to each of the PA hybrids and solder to the pads on the new PA boards.
- 20) Recover the PA screen and carefully solder the 5 control wires to each board according to the following code:-

Red	+13.8V
Orange	T9V
Yellow	AFP
White	ALC
Blue	Preamp
- 21) Pass the new RF cables through the holes in the Screen, as shown below.

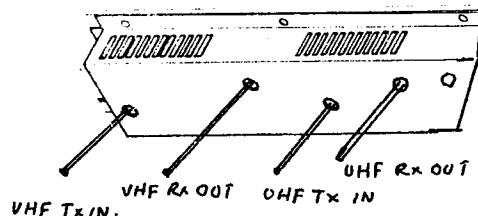

- 22) Secure the screen to the heatsink using the original screws. Remember that the centre top location is left blank for the earth wire when the heatsink is installed in the rig.

- 23) Place the heatsink assembly to one side. Return to the main chassis and remove the remainder of the plug in connectors from the 70 cms main unit. Remove the main unit pcb from the chassis. Using the M3 tap provided cut a thread in the three holes marked 'A' in fig 2. Remove C129 from the 70 cms main unit. See fig 4 for the location of this component. Solder one of the white L.O. cables to the main unit as shown, the screen of the cable should be soldered to the vco screen and the core to the junction of D12 and R99. Desolder the original 1st IF input cable - this is no longer required. Replace the main unit in the chassis and secure with 2 self tappers in the holes nearest the front of the rig. Reconnect all of the plug in cables except J15 which will be connected to the new board. Carefully unwind the wire loops that secure the first LO cable along side the Tx strip screen.
- 24) Carefully remove all of the plug in connectors from the 2m main unit and remove the unit from the chassis. With the M3 tap cut threads in the three holes marked 'B' in fig 2. Desolder and remove C11 from the 2m main unit. Solder the other LO coaxial cable as shown in fig 5, the screen should be soldered to the screen of the VCO. Replace the unit in the chassis, again securing the unit with the two self tapers nearest the front of the rig. Replace all of the plug in connectors except J02 which will be connected to the new board.
not abt screen "a" (2)
- 25) Carefully ease the heatsink back onto the main chassis and secure with the 3 long screws '1' and the two short screws '2'. from the kit supplied, locate the 6 M3 pillars and install these in the 2 and 70 main units. Restore the black earth wire to the centre top of the PA screen. Restore the two connectors to the 9 Volt regulators. replace the main 13.8V feed to the PA units. Solder the 10uF capacitor to the tag strip at the rear of the transmit board, where the 13.8 volt wire is connected to a large toroid. OBSERVE POLARITY. this capacitor reduces a lot of broad band noise from the switch mode supply.
- 26) Reconnect the thin Blue and Red wires to the little pcb's mounted on the feedthroughs on the PA screen. (Reverse instruction 4).

EN4 01769
289213

27) Starting with the 2m main unit replace the following connectors:-

- i) J04 Tx output
- ii) J05 PA control

Continuing with the 70 cms main unit replace:-

- iii) J10 Tx output
- iv) J06 PA control

28) At this point you are now ready to install the muTek front end boards. These fit on top of the nylon pillars. Starting with the 2m board, secure the board to the pillars with the M3 X 6 screws provided. The central screw by the L.O. input should secure the remaining black earth wire from the PA screen. Plug the antenna connector in the socket marked V.H.F. IN. The red coded coax should be connected to the socket marked L.O. in. Solder the flying lead from the +12V pad to the red +13.8 V wire on the P.A. feedthrough. connect the plug from J02. Ensure that the blue wire is towards the rear of the rig. A moderate amount of force will be required the first time this connector is inserted.

29) Secure the 70cms board to the pillars over the 430MHz main unit with the remaining M3 X 6 screws. Make sure that the white coded cable is lead between the side of the new board and the 430MHz PLL unit. Also make sure that the 1st L.O. and the J15 connectors are accessible. Connect the Antenna cable to the socket marked UHF in. Connect the 1st and 2nd L.O's to their appropriate connectors. Connect J15 to the 3 pin header, orientation is not important. Use the Blue coded I.F. link cable provided to connect the I.F. output on the 70 cms board to I.F. IN 1 on the 2m board. This completes the installation.

30) Taking care to avoid the mains protection board, set up the FT 736 and connect the 2m output to a power meter and dummy load. Select 145.000 MHz and FM mode. If the S meter reads above S1 then it should be set back to this reading by adjusting the IF Gain pot (Fig 8) on the 2m muTek board.

31) Reduce the Tx Drive control to minimum and select Transmit mode using the MOX switch. Advance the drive control until a reading of just over 25W is obtained. On the 2m main board adjust VR 02 for a reading of exactly 25W. Adjust VR 04 for a reading of 8 on the Po meter. Using a DVM probe the anode of D32 and adjust VR 03 for a reading of approximately 1 volt. Deselect MOX.

Transfer the Dummy load to the U.H.F. antenna connector. Select 435MHz and FM mode. Reduce the drive control to minimum and select MOX. Advance the drive control until a reading of just over 25W is obtained. On the 70cms main board adjust VR 04 for 25W, VR 06 for a reading of 8 on PO meter and probing the wire link between D19 and VR 04, adjust VR 05 for a reading of about 1V. This completes the alignment. Replace the top and bottom covers, not forgetting to reconnect the loudspeaker connector.

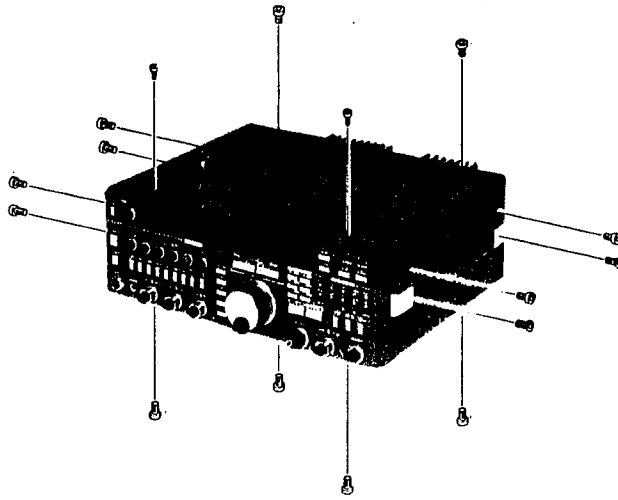

Figure 1

Location of case screws

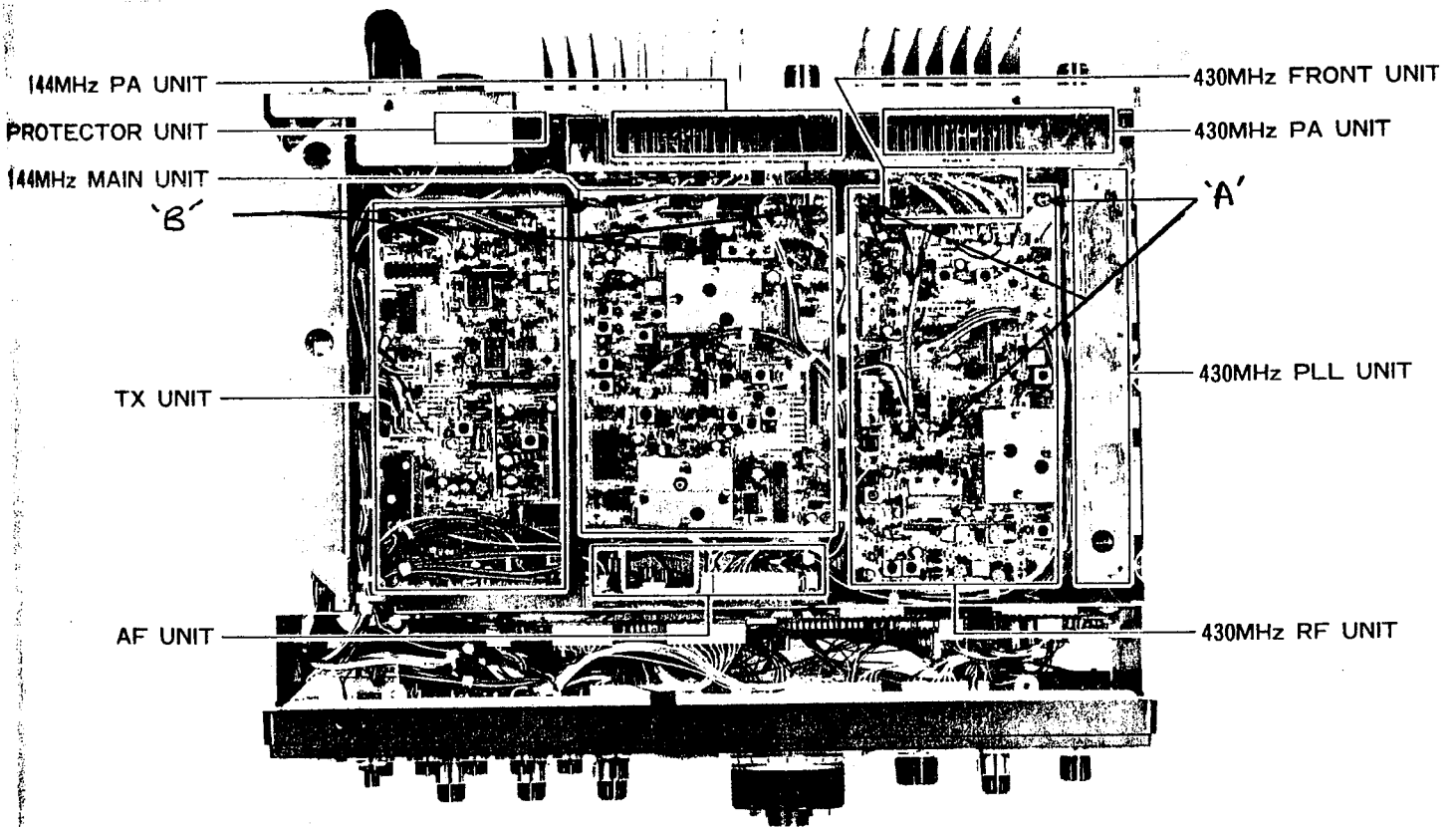

Figure 2

Location of units in FT 736

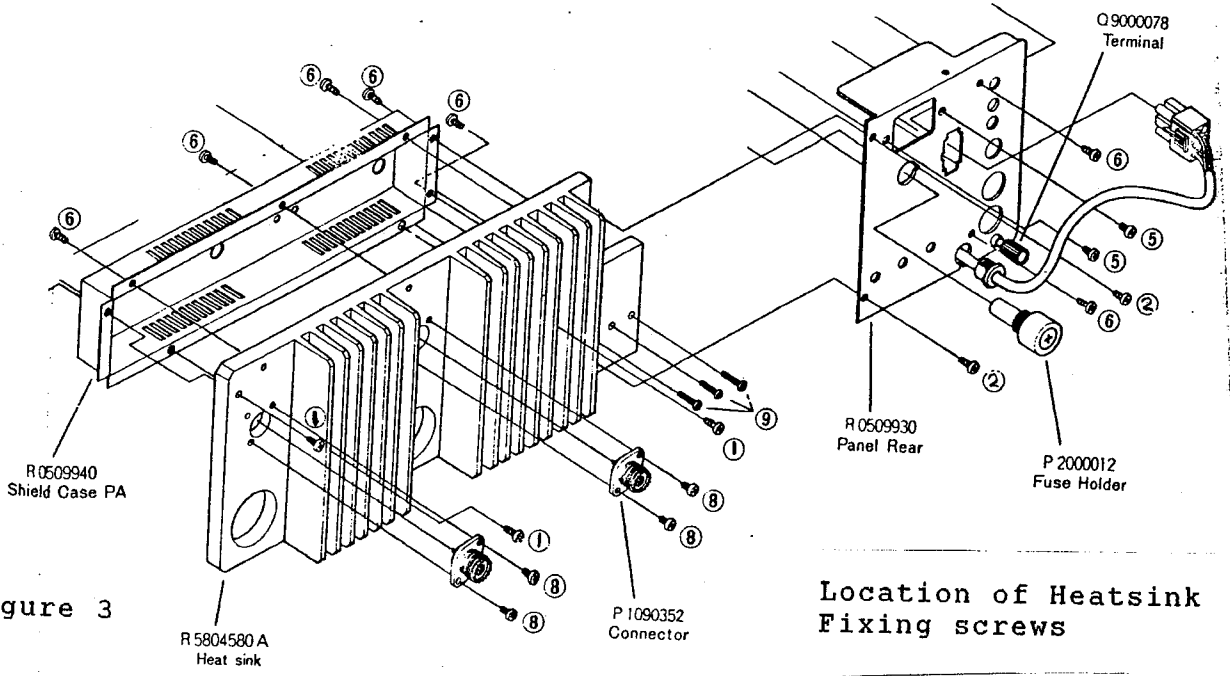

Figure 3

Location of Heatsink Fixing screws

430MHz RF UNIT (No. 7XXX)

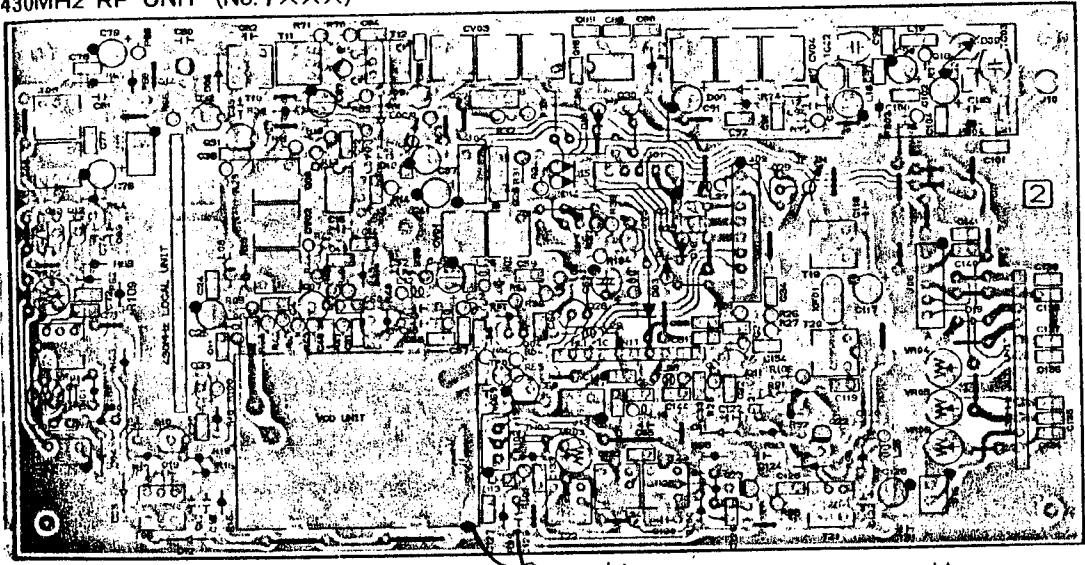

Figure 4

Component side

144MHz MAIN UNIT (No. 6XXX)

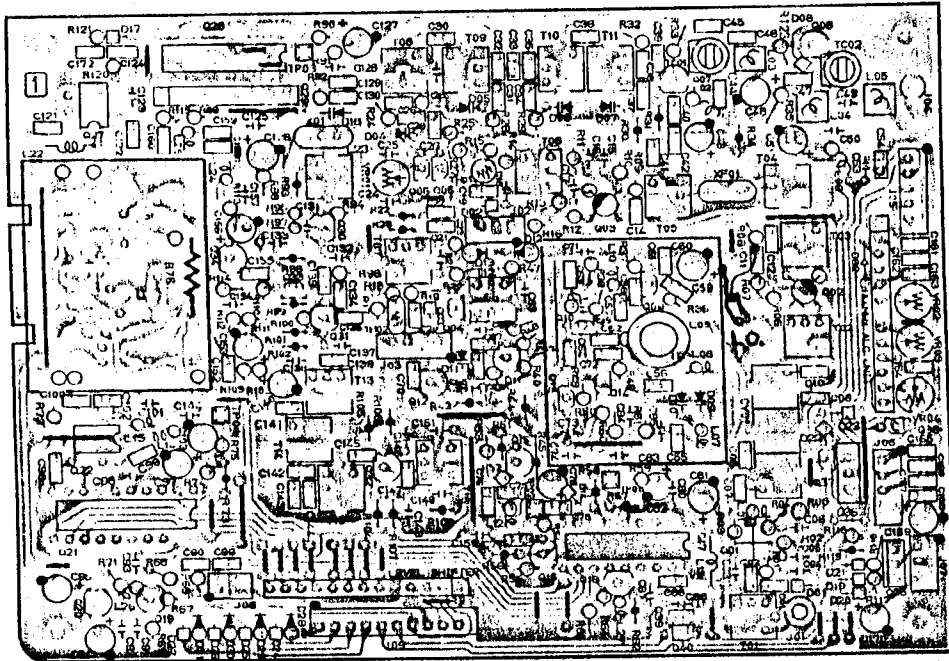

Figure 5

Component side

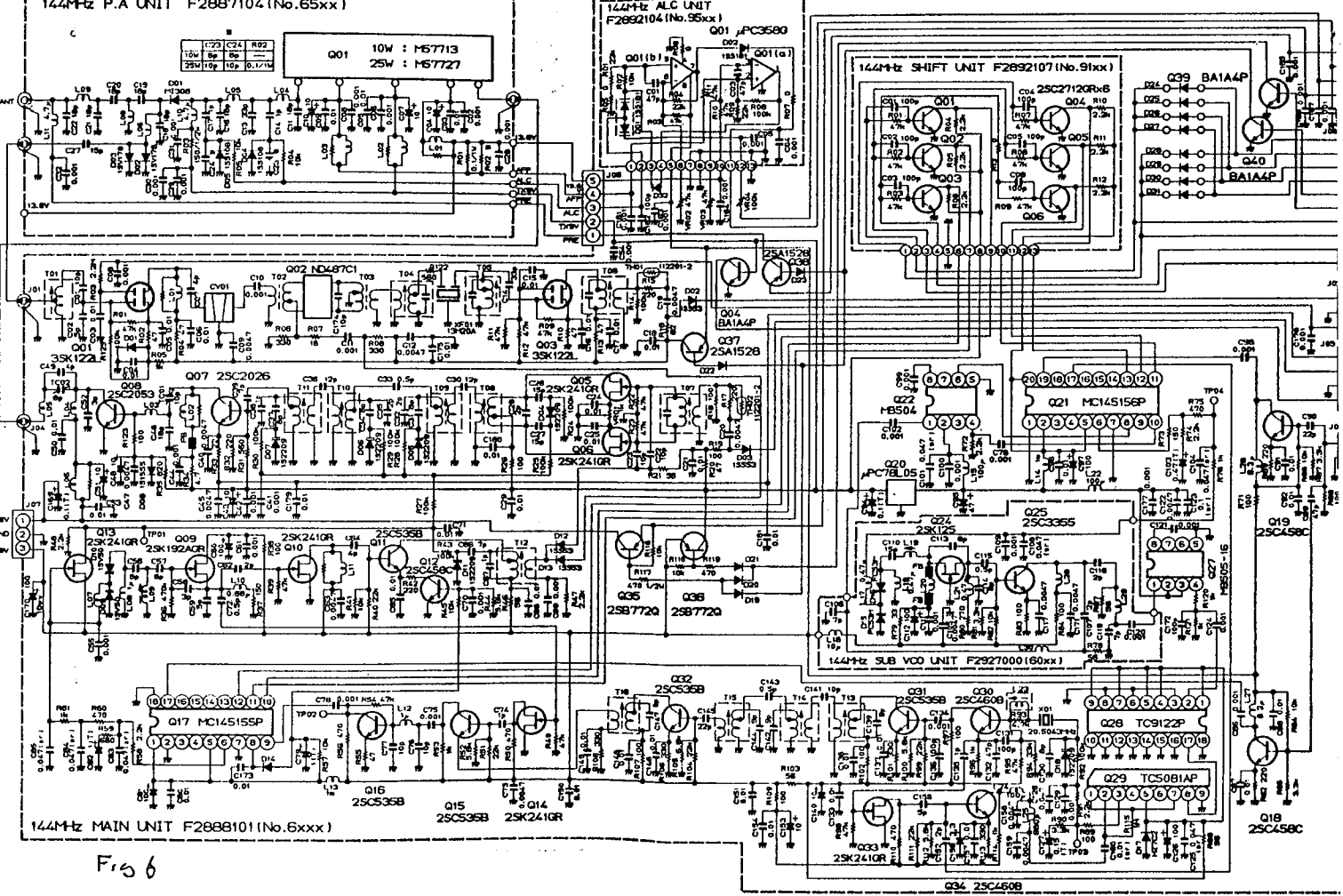
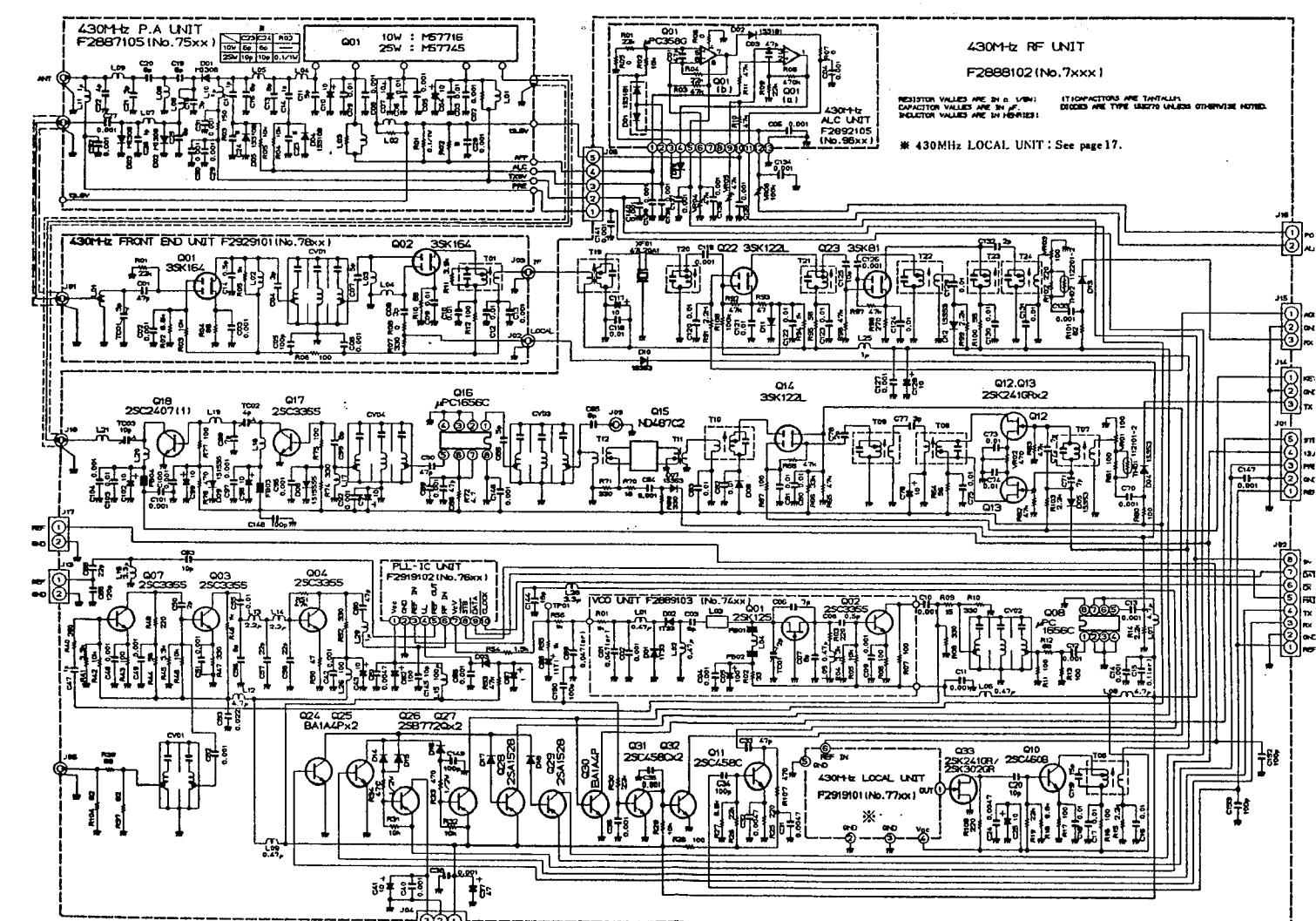

Fig 6



RESISTOR VALUES ARE IN OHMS UNLESS NOTED OTHERWISE.
CAPACITOR VALUES ARE IN P.F. UNLESS NOTED OTHERWISE.
INDUCTOR VALUES ARE IN MICROHENRIES.

† FACTORS ARE TENTATIVE UNLESS NOTED OTHERWISE.

* 430MHz LOCAL UNIT: See page 17.

Fig 7

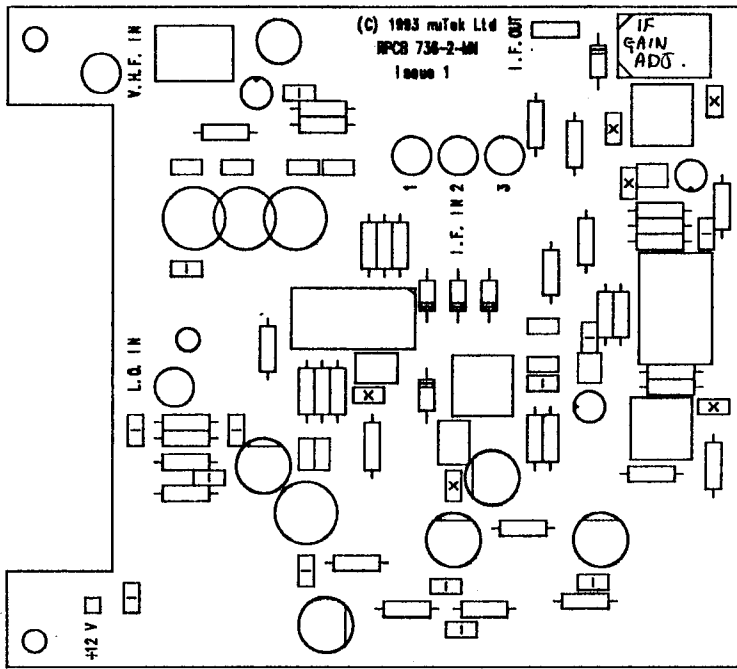

Fig 8 2m muTek board

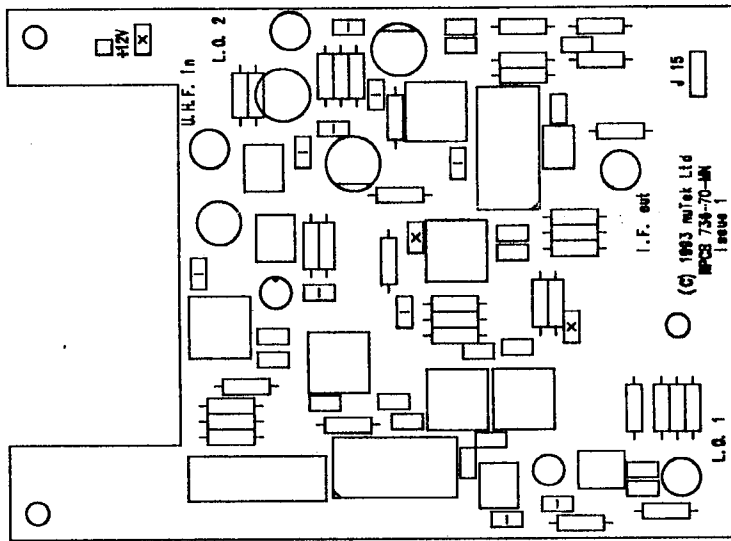
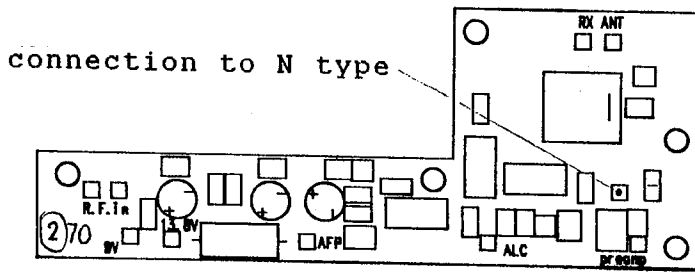
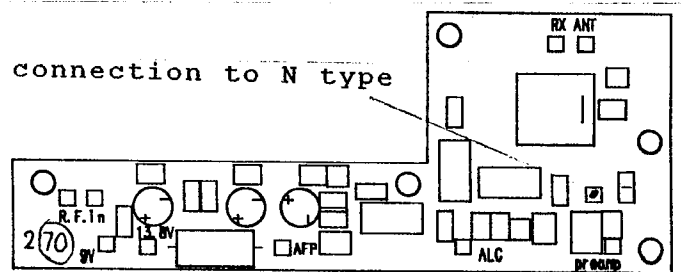

Fig 9 70 cms muTek board



2m P.A. board



70 cms P.A. board

Fig 10

736 2m main pcb

Revised: February 4, 1993
Revision: 1

Item	Quantity	Reference	Part
1	2	R2,R9	10R
2	1	R6	18R
3	1	R12	51R
4	7	R8,R17,R18,R24,R26,R29, R33	100R
5	2	R10,R34	150R
6	2	R5,R4	220R
7	1	R35	390R
8	2	R1,R3	470R
9	1	R19	1K5
10	3	R20,R28,R?	2K7
11	2	R11,R21	3K3
12	1	R7	4K7
13	3	R27,R32,R36	10K
14	5	R15,R16,R22,R23,R31	39K
15	2	R14,R30	82K
16	2	R13,R25	1M0
17	1	C7	6p8
18	1	C26	8p2
19	2	C1,C3	12p
20	1	C8	33p
21	1	C12	39p
22	1	C10	68p
23	1	C2	100p
24	13	C4,C5,C6,C9,C11,C13,C15, C19,C20,C21,C22,C24,C25	1n0
25	6	C14,C16,C18,C39,C40,C?	10n
26	1	C23	1/5p
27	2	L1,L10	220uH
28	4	L5,L6,L7,L9	5.5T
29	3	L2,L3,L4	KACS4520
30	2	Q3,Q8	2N3906
31	1	Q4	BF199
32	3	Q1,Q2,Q5	BF988
33	2	Q6,Q7	MPSA18
34	5	D1,D2,D3,D4,D5	1N4148
35	1	X1	SBL-1
36	1	XF1	FILTER
37	1	L8	TAPIND
38	1	JP1	HEADER 3
39	5	J8,J2,J3,J4,J6	SMJ

Item	Quantity	Reference	Part
1	1	R9	8R2
2	2	R3,R11	10R
3	2	R10,R48	22R
4	1	R36	27R
5	1	R38	47R
6	1	R23	51R
7	4	R4,R32,R40,R41	100R
8	2	R37,R39	120R
9	2	R46,R45	220R
10	1	R33	330R
11	1	R8	390R
12	2	R1,R2	470R
13	1	R34	1K0
14	2	R7,R12	2K2
15	1	R42	2K7
16	1	R30	4K7
17	3	R43,R44,R47	10K
18	1	R35	12K
19	1	R31	33K
20	1	R6	39K
21	1	R5	82K
22	1	C2	2p2
23	1	C1	8p2
24	1	C27	10p
25	1	C28	12p
26	1	C32	22p
27	5	C33,C17,C30,C35,C46	33p
28	2	C16,C26	68p
29	2	C15,C36	100p
30	2	C31,C34	120p
31	11	C3,C4,C6,C7,C8,C9,C10, C12,C29,C37,C39	1n0
32	4	C13,C14,C38,C47	10n
33	1	C5	1/5p
34	1	L1	100-071
35	2	L13,L12	100-076
36	1	L14	.33uH
37	1	L8	0.5T
38	1	L7	2T
39	2	L2,L3	3T
40	3	L9,L10,L11	BEKNK 4028
41	1	FL1	7HT
42	1	Q8	2N3906
43	1	Q3	BF199
44	1	Q1	BF988
45	2	Q2,Q4	BFR96
46	1	Q7	MPSA18
47	2	X1,X2	SBL-1
48	1	P4	PIN
49	4	J02,J01,J03,J04	SMJ
50	3	L19,L20,L47	150uH

Item	Quantity	Reference	Part 2m	Part 70 cms
1	2	R6,R7	10K	10K
2	2	C11,C12	1p0	1p0
3	2	C9,C10	10p	10p
4	1	C1	22p	4p7
5	1	C4	22p	6p8
5	2	C3,C2	39p	8p2
6	5	C6,C7,C14, C16,C18	1n0	1n0
7	3	C13,C15,C17	10u	10u
8	1	L2	1uH	1uH
9	1	D3	BAS 16	BAS 16
11	1	RL1	RELAY DPDT	RELAY DPDT
13	2	D6,D7	BAS16	BAS16
14	2	R8,R9	OR1	OR1
15	3	L4,L5,L6	5T Ag	1.5T Ag
16	1	U1	M57727	M57745

Note Pins 2 & 3 change function between the M57727 and the M57745. The circuit Shows the correct orientation for the 2m amp. These pins are reversed on the 70cms amp.

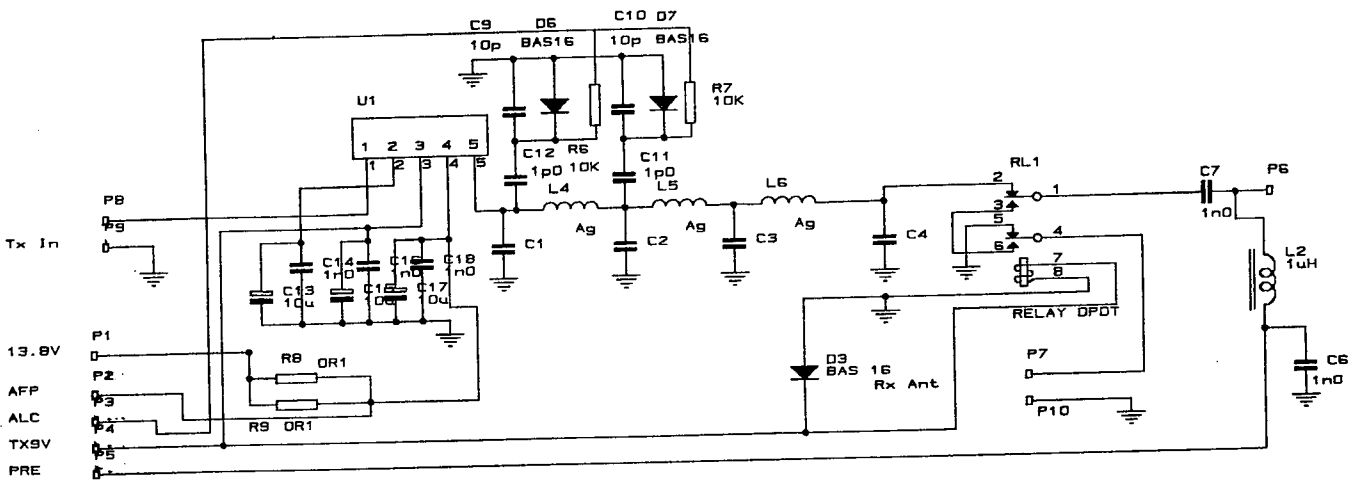

Reference	2m	70 cms
U1	M57727	M57745
L4, L5, L6	5T	1.5T
C1	22p	4p7
C2, 3	39p	8p2
C4	22p	6p8

Fig 11
P.A. board schematic diagram

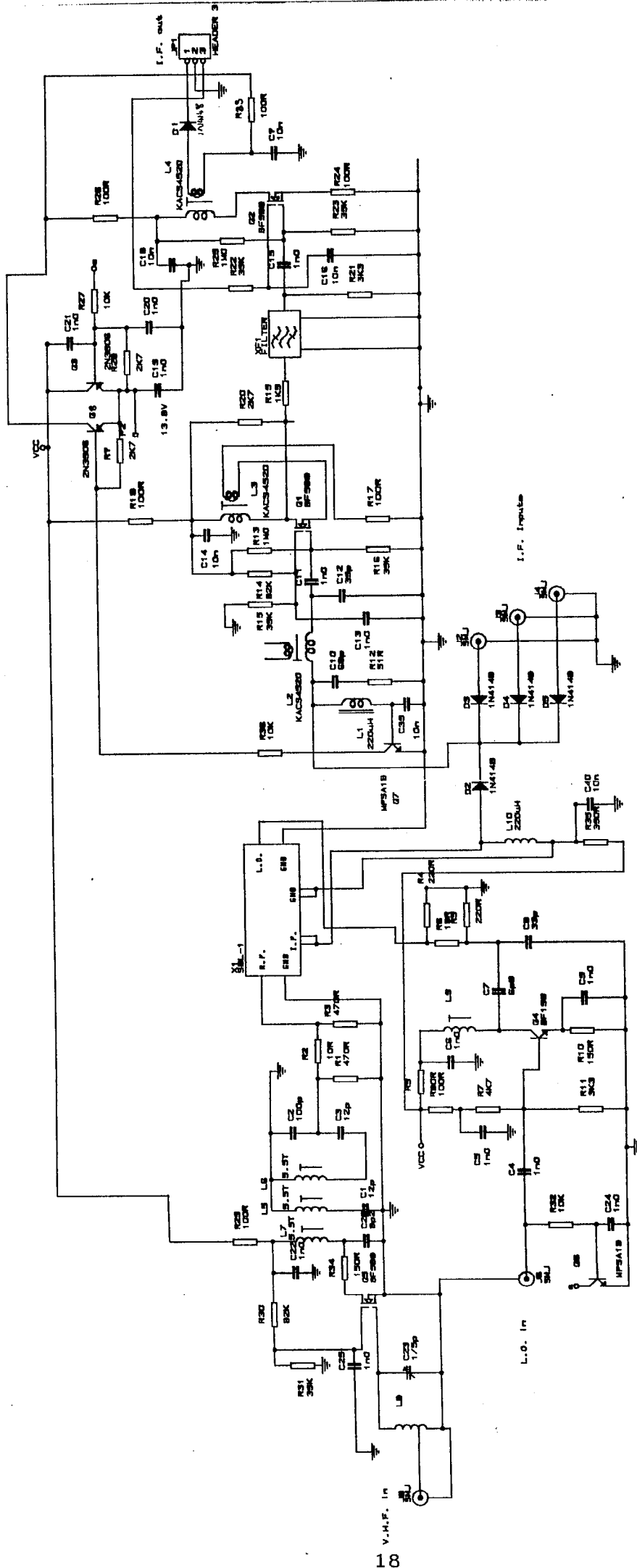

Fig 12
2m muTek board schematic diagram

