



The F6BVA 3cm-UHF Transverter Kit Project

Michel F6BVA introduced his 3cm to UHF transverter more than a decade ago. I saw a posting on the French “hyper” email forums asking for subscribers to a group purchase of immersion-silver PCBs via Pierre-François F5BQP. I subscribed and asked a few friends if they were also interested. One thing led to another and now we have an Anglophone group of more than eighty who are taking part in a group buy of PCBs, cases and parts. This latest version of the PCB uses an immersion-silver finish on Rogers RO4003C PCBs.

In his French-language introduction to this version, Michel says:

“Ten years after the first prototypes of the 3cm to UHF transverter were built, a new run of silver-plated PCBs has arrived from China. It feels like a good time to re-assess the circuit design. The devices used in the original (NE32584C) are not hard to find, but several builders have bemoaned the poor quality of some of the “non-genuine” devices which have been supplied. I took the opportunity of this review of the circuit to try some newer devices.

The CE3512K2 device which has been selected should not suffer from supply problems for a considerable time ahead. Using this device has required some minor changes to the design.”

I have paraphrased Michel’s instructions for an English-speaking audience. Some of the text is a very loose translation of his original words from several different documents. Some is based on my own experience of building several of these units. Where there is a difference that I don’t explain in detail, it is probably a mistake, and Michel’s original text must be considered the master document. Please send details of any errors or omissions to me for rectification.

Neil Smith G4DBN May 2021

Email: neil@g4dbn.uk

Twitter: [@g4dbn](https://twitter.com/g4dbn)

Blog: <http://g4dbn.uk>

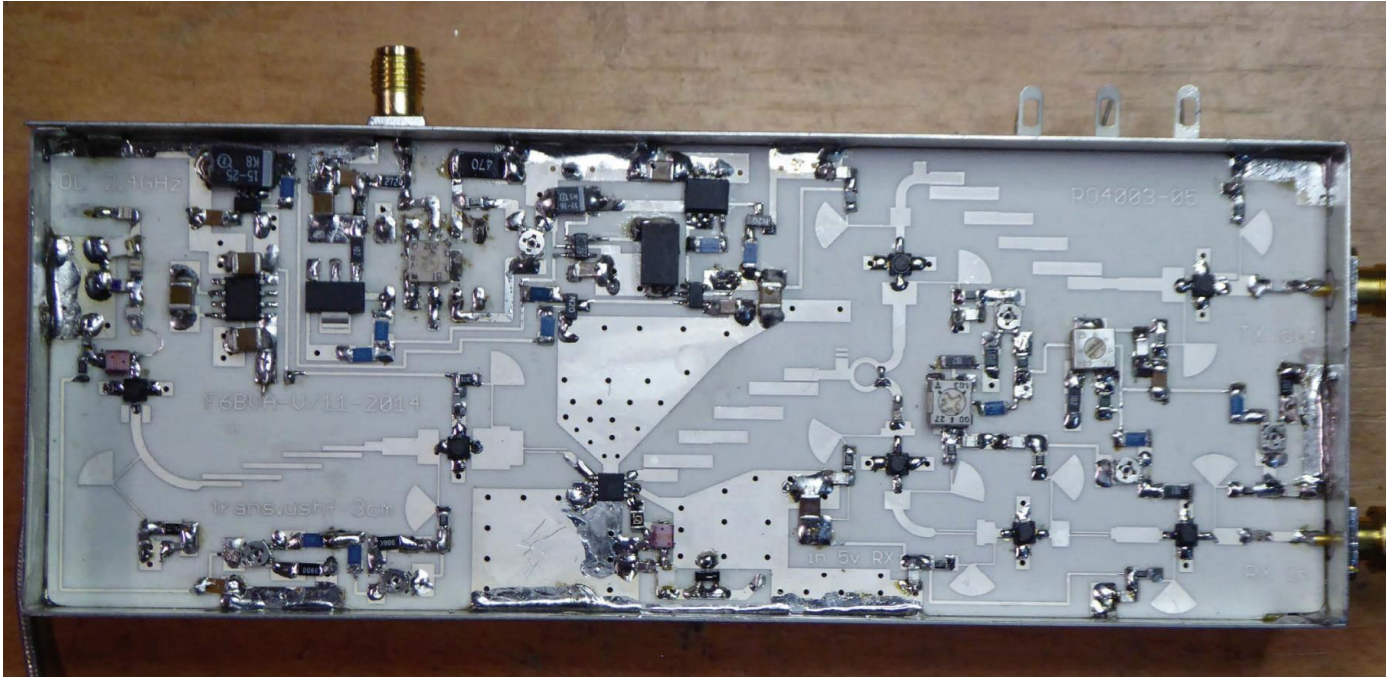

The original assembly instructions (in French) are at

<http://f6bva.pagesperso-orange.fr/Technique/trans%20uhf%20vers3cm/Transverter%20UHF10GHz%20V11-2014.pdf> and <https://f6bva.pagesperso-orange.fr/Technique/trans%20uhf%20vers3cm/dossier%20print%20Ag%20complet.pdf>

Michel issued some changes around filtering of the bias line, originally published in “Revue Hyper BULLETIN N° 278 avril 2021” and available at <https://f6bva.pagesperso-orange.fr/Technique/trans%20uhf%20vers3cm/adaptation%20DF9NP%20dans%20transverter%2010GHz%20.pdf>.

The main changes from the original version are:

- 1) Modified bias chain for the new pHEMTs.
- 2) Some semiconductors have been changed (high-side switch for example)
- 3) Some package sizes differ from those in Michel’s photos.
- 4) The modification published in the April 2021 issue of Revue Hyper to reduce spurs with an internally mounted local oscillator board ins included.
- 5) DC-over-coax and external PTT to ground are implemented, but VOX is not.

PTT modifications

I have supplied the components to implement DC-over-coax PTT, but as an option in my build I fitted a 1nF feedthrough to give an external “ground to transmit” input. It is protected against positive spikes by a series diode and can survive in excess of -50 V negative spikes. The PTT port sits at around 5 V and will switch to transmit at 2 V or lower. The active device is a PNP SOT23 transistor BC856A. The circuit model in QUCS Studio <http://qucsstudio.de/> shows the transfer function. The kit includes all parts for these two options, which will work perfectly if both are implemented. If you wish to use Michel’s original VOX circuit, the details are in his PDFs.

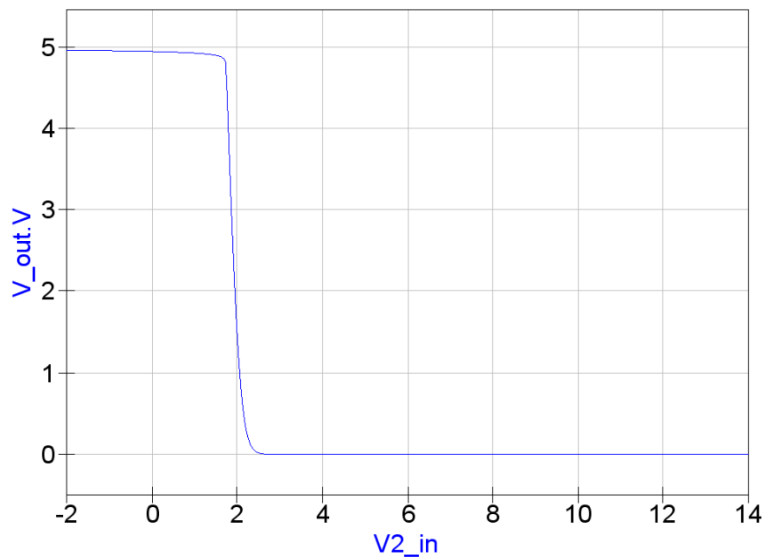
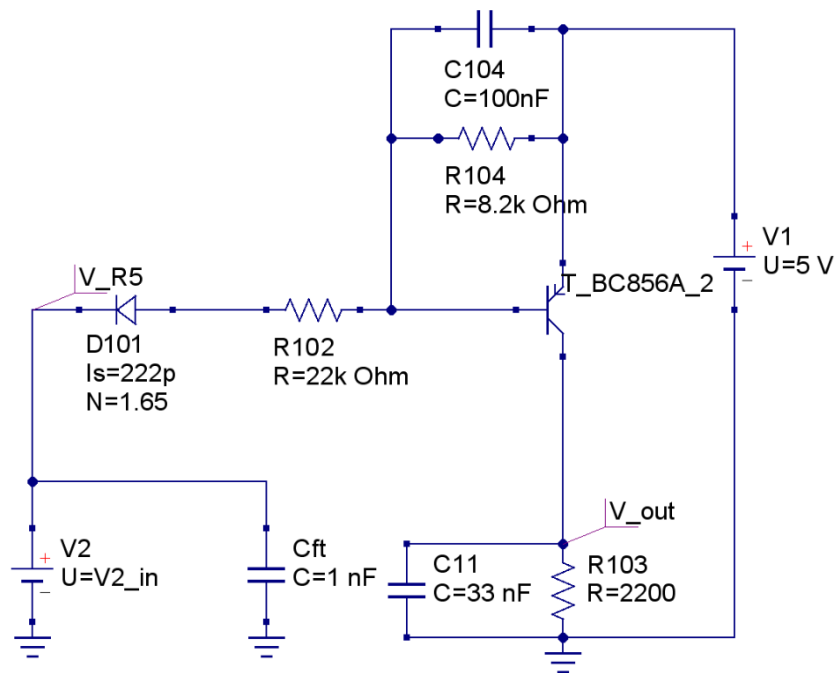

dc simulation

DC1

Parameter sweep

SW1
 Sim=DC1
 Type=lin
 Param=V2_in
 Start=-2 V
 Stop=14 V
 Points=400

Preparation

Check the components taped to the card are all there. Check the bag of parts to ensure you have all the loose parts. They are listed on the sheets, and I will have ticked the box to confirm the parts are in the bag.

I have included 0.3mm multicore solder, hook-up wire and 1.13 mm grey coax. You will need to provide suitable soldering equipment and some thicker multicore solder for seam soldering etc, perhaps some liquid flux (simple rosin is fine), isopropyl alcohol or acetone, plastic gloves or tissues to protect the PCB silver plating, suitable tweezers and perhaps some cocktail sticks or sharpened matches for holding the parts while they are being soldered. You will need a fine-toothed file or 180-grit abrasive paper to file small flats on the PCB corners and 5 x 0.1 mm corner reliefs. You will need to make a 7mm spacer block from card or wood or MDF or something and optionally, you may need to drill two small (0.7 to 1.0 mm) holes in the PCB. You need either stunning eyesight or a viewer, magnifier, or long-distance microscope. None of the parts other than some porcelain RF caps are smaller than 0603, so this isn't an impossible fiddly project. There is no solder

resist and many of the pads are incorporated into blocks, so it is probably just about impossible to use solder paste and a reflow oven or even hot air.

I usually lay a sheet of kitchen towel on my bench when I'm doing SMD assembly, so any components that I drop will land on the paper towel and not bounce and disappear into the carpet.

I will keep a stock of all but the expensive parts to send out in emergencies. Everything is available from Farnell, Mouser, Digikey or RF-Microwave if I run out. Get some really good tweezers and soft wooden toothpicks or sharpened matchsticks and only remove parts from the tapes or bags right before you use them. Be aware that some of the resistors and almost all of the capacitors are not marked with their values.

Finding the locations of some of the parts can be challenging. I have tried to help with plenty of diagrams and photos, but I fully expect a lot of questions via the BVA-Transverters-uk email list. If there are areas that prove tricky, I'll consider running some Zoom sessions to help those of you who are newcomers to microwave manual SMD construction.

The parts that come on tape are fixed down to the parts list sheets with clear Sellotape. Use a scalpel or craft knife to remove the strips from the page before trying to remove the cover from the component tape. I peel back the cover using tweezers in a rolling fashion, so there is no chance of the thing becoming a catapult. I only take out one component at a time. OK, enough of the sermon. Enjoy the build.

Box

If your box is not pre-drilled, use the diagrams in [appendix *****](#) to mark the holes and drill them.

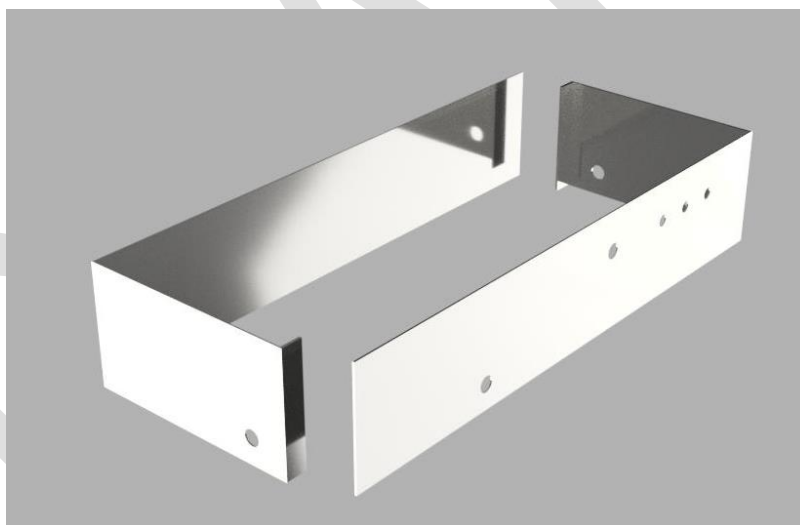

I drill the SMA holes to 4.1 mm, but 3.3 mm (same as the feedthrough caps) is fine if you cut the PTFE on the rear of the SMAs flush with the flange of the socket. Take great care to get the orientation and hole location right! I put marker-pen spots using the drawings as a reference, so I don't make a silly mistake when doing the detailed marking out. If drilling manually, I use some masking or drafting tape and mark the drilling positions on the tape, then make a light centre-punch mark. The tape helps stop the drill from slipping and scratching the metal but is not a perfect fix. Use a sharp drill and consider using a piece of scrap metal with a hole of the right size clamped over where you are drilling, so the drill cannot slip. Use a piece of MDF or hard wood underneath so the tinplate doesn't tear. De-bur the holes. If the edges of the hole are distorted, use a couple of light taps with a hammer against a metal block to flatten the tinplate.

Clean the tinplate with isopropyl alcohol or acetone. Using gloves or recently-cleaned hands, assemble two sides and one of the lids. Use a bit of soft iron wire, a croc clip or tape to apply pressure if you can't get the

corners closed up for soldering. Solder the top corners of the sides together. I use a little liquid rosin flux to help the solder flow at the corner joints. When the joints cool, fit the other lid, removing the first one.

Make sure the box is sitting nice and flat, and that the seams are closed tightly together and well aligned, solder the other corners. Check both lids both fit properly! This will save a world of pain later. Check that the lids fit both ways round and when swapped top to bottom. If they fit best in a particular orientation, use a marker pen to put a dot on one end of the case and one lid and a pair of dots on the other end and lid so you can always fit them the right way round. If you've done the job right, both lids will fit either way round.

PCB Preparation

To ensure the correct performance and stability, the PCB must be installed at 7 mm above the bottom of a Schubert tinfoil box.

PLEASE ENSURE THAT YOU USE PLASTIC OR COTTON GLOVES OR TISSUE WHENEVER YOU TOUCH THE SILVERED FACES OF THE PCB. The silvering is extremely thin and acid from your fingers will damage the layer.

Check the alignment of the PCB and taking great care not to touch the PCB with your bare fingers, file or cut off a 5mm x 0.5 mm rectangle at the corners where the box seams will be. The PCB *will not fit* unless you do this.

PCB Preparation – Internal LO board

If you are using an internal local oscillator board like a bare DF9NP unit, you need to drill a small hole (0.7 mm approx) through the bare square in the ground plane of the PCB adjacent to where C40 would fit on the component side.

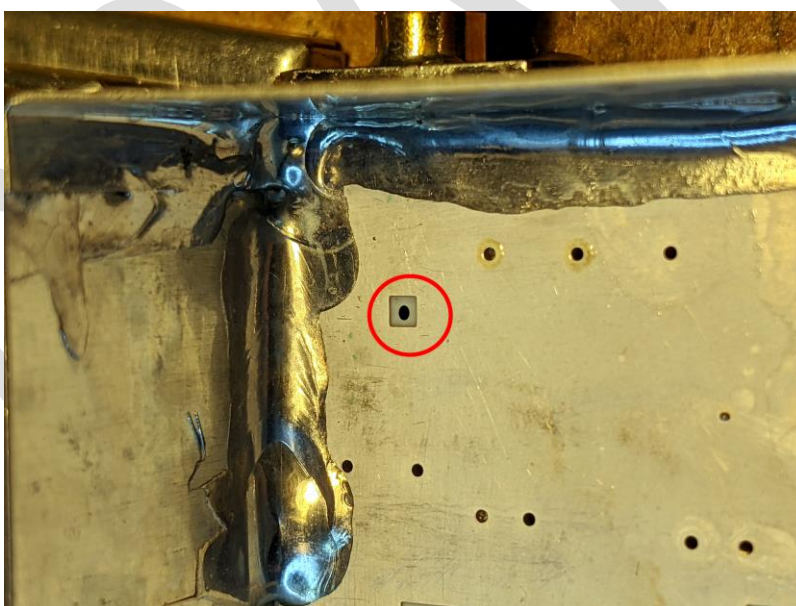

Figure 1 Location of the hole for the LO coax for internal LOs only

This will permit the DF9NP board LO output to be fed through to the LO input port.

PCB Preparation – PTT connection

If you are intending to fit a PTT input connection, you will need to drill a 1mm hole in the PCB adjacent to the track running past R6. This is to allow the lead of the wire-ended resistor R102 to pass through the PCB in some insulated sheathing.

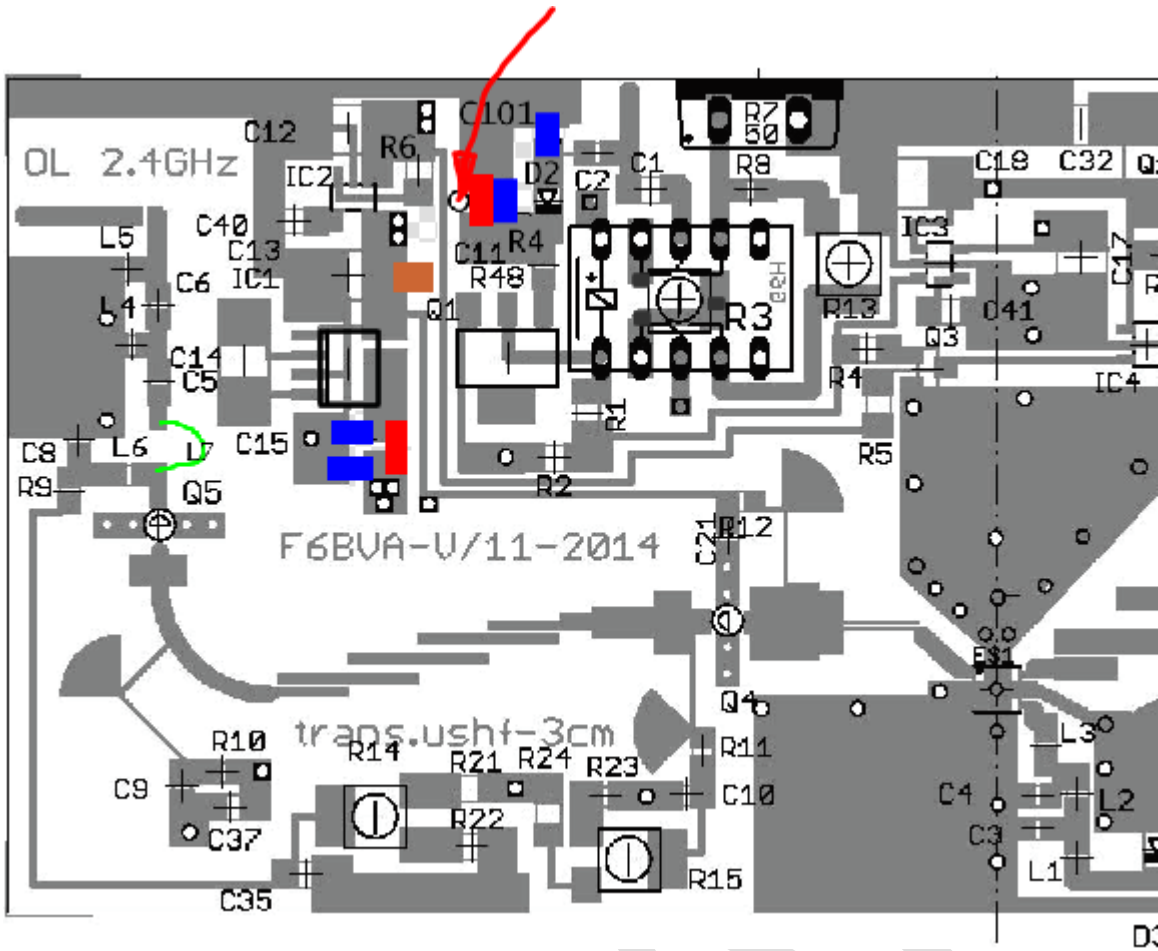

Figure 2 R102 1mm hole drill location

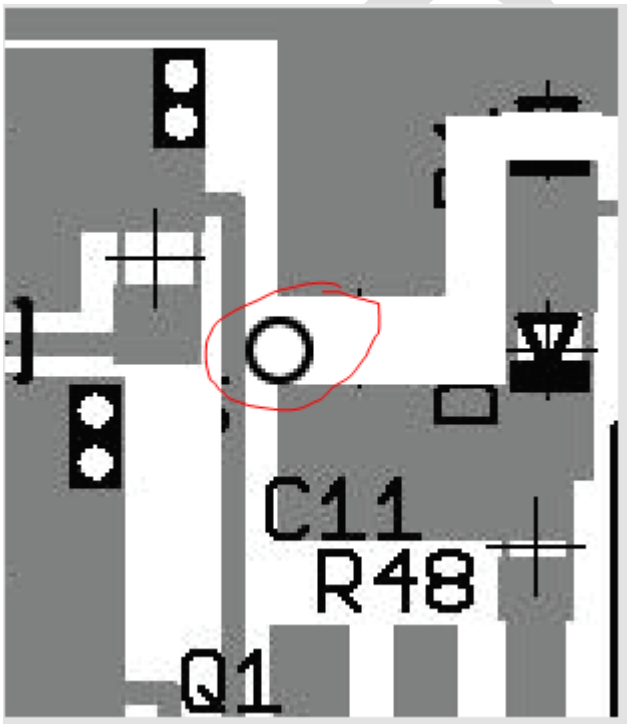
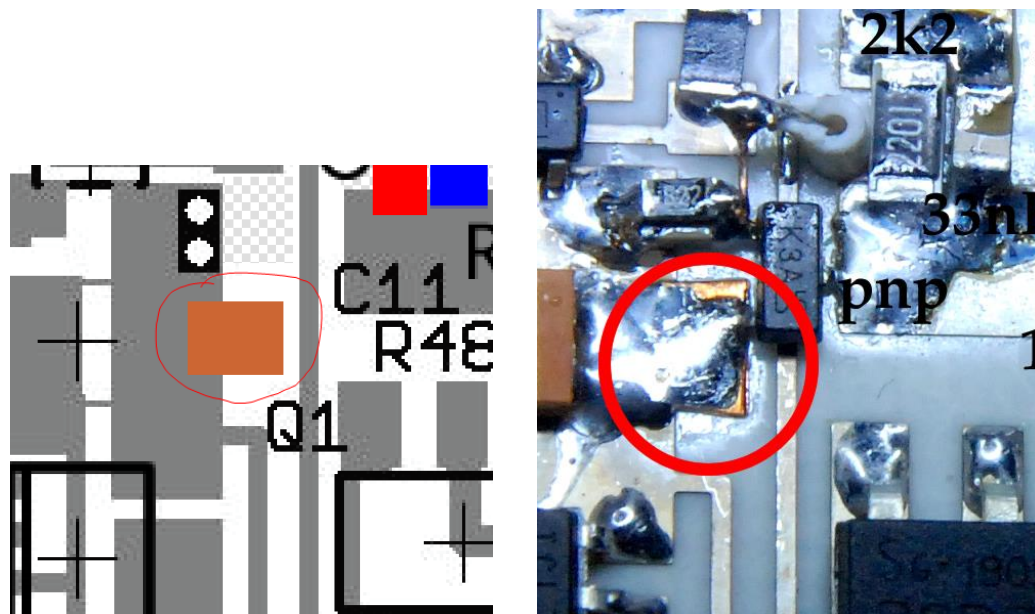

Figure 3 Close-up of R102 1mm hole drill location

To connect Q101, you need to solder a piece of copper foil adjacent to the end of C13



PCB Prep – Internal OCXO modification

Michel published a mod for the 3cm-UHF transverters in the April 2021 "Revue Hyper" to fix a problem identified with using internally-mounted LO boards. I have purchased components and special cable for this fix, which I would recommend doing even if you are using an external LO device, but it is up to you.

The problem is related to pickup of spurs on the negative bias rail. The modification consists of cutting one pad, fitting a resistor across the gap, adding a bypass capacitor, and replacing the ground-plane side power wires with thin shielded cable. I will supply suitable 1.13 mm coax for this as part of the kit.

The mod is easy, just needs a steady hand. This is the relevant part of the board, just below the ICL7660 negative bias generator.

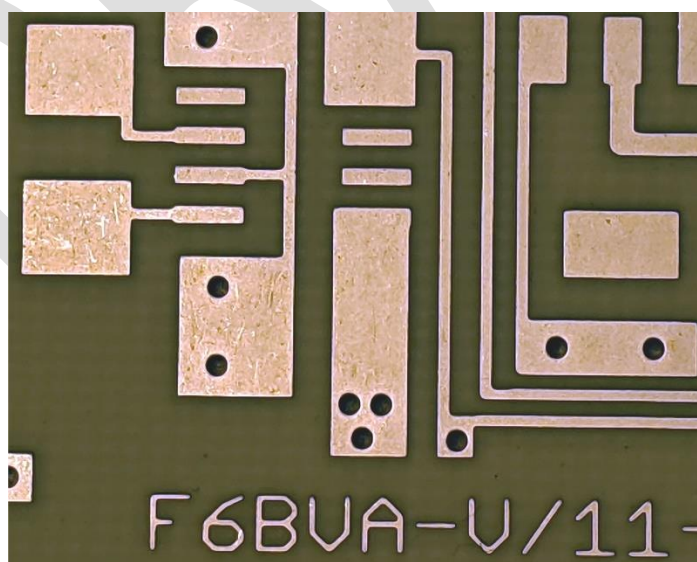

The track needs a slice a little less than 1 mm wide of the copper removing, I used a scalpel, making two deep parallel scores, then peeling away the foil like this:

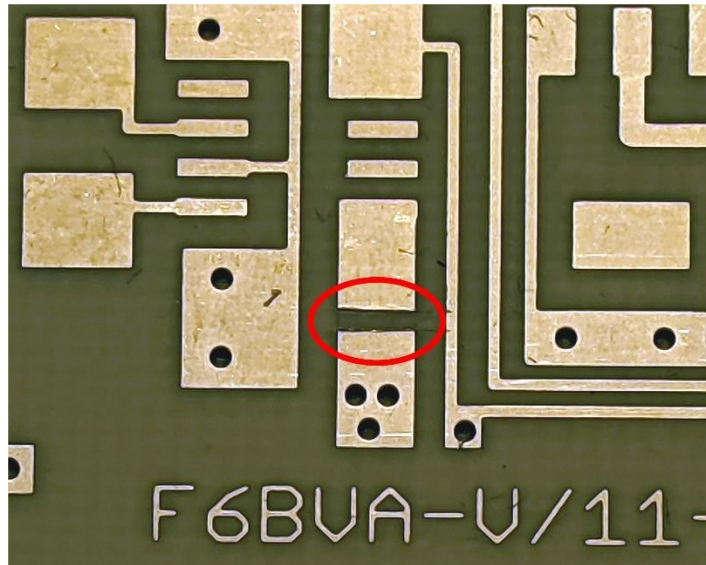

The two new components need to be fitted as below.

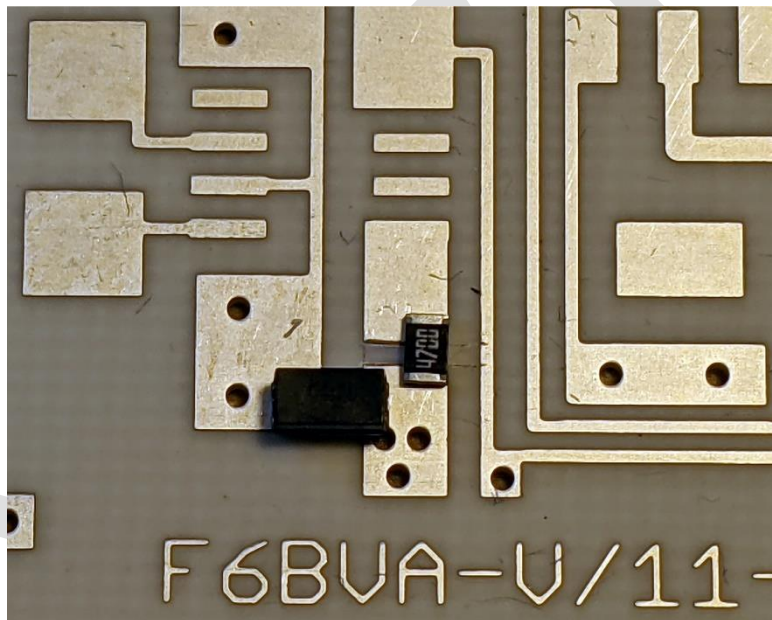

When it is time to fit the passive components, I recommend soldering both ends of the 470 ohm resistor R105, but only the earth side of the cap C103 (which is a ceramic 10 μ F so polarity does not matter). Solder the end of the cap near the three holes later, when you fit the jumper wires. That avoids a world of pain with the holes filling up with solder.

Before fitting the PCB

There are some parts which are difficult to solder when the PCB is soldered into the box. I suggest you fit these before you seam-solder the PCB.

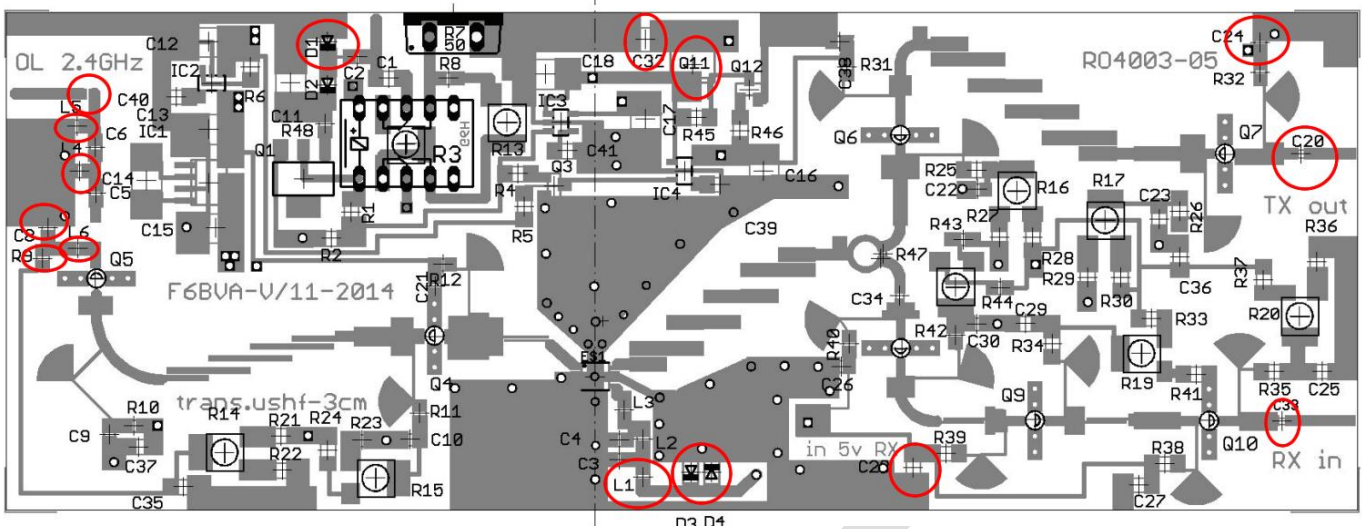
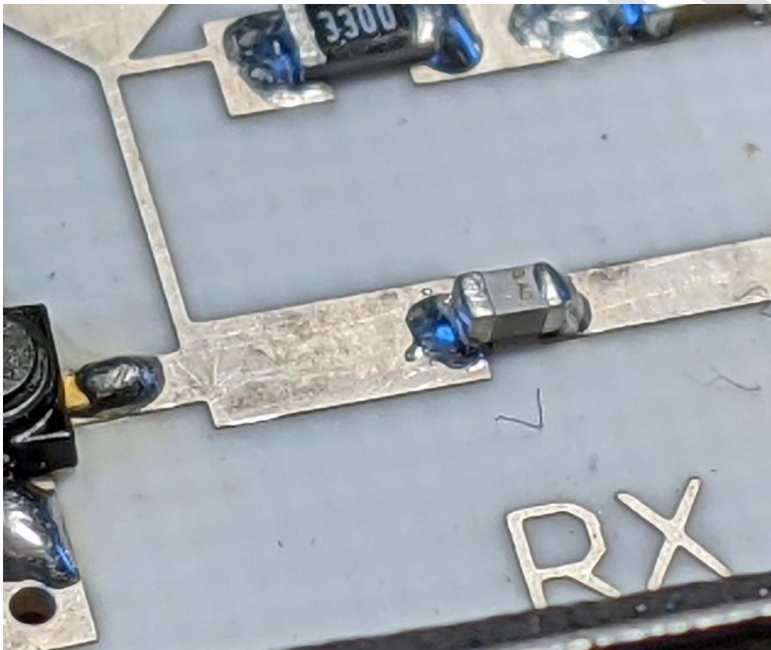

Figure 4 Components to be soldered before fitting the PCB into the box

I find it best to fit L5, L4, L6, C8, R8, C35, C101 (marked as "D1" on the original layout), C32, C24, C25, C27, C28, C33, D3, D4 and L1 before fitting the PCB into the box.

C20 and C33 are probably the most critical capacitors, so it is also useful to solder them in place before seam-soldering the PCB into the box. They need a *very* small solder fillet, and you should try to avoid letting solder run along the PCB track if at all possible, to reduce losses.



The fillet at the end of the capacitor closest to the pHEMT is not good. I used too much solder and it looks like the capacitor is slightly raised at that end. I should really remove the cap, mop up the solder with de-soldering braid and refit the cap, but life is too short.

Fitting the PCB into the box

One simple way to get the spacing from the bottom of the box correct is to use a 7mm thick spacer made from a piece of plywood or a stack of cardboard slightly smaller than the PCB. I recommend that you do NOT fit the lid while doing this, as it is too easy for things to go badly wrong. If the inside face of the box has been touched since it was cleaned, give it a wipe with IPA or Acetone, and do the same to outer sections of the PCB.

Note that this spacer will make the component-side face of the PCB 7mm from the top face of the sides, not from the lid, so you might want to make the spacer 6.5 mm if the lid has internal bend radii. Thanks to Dave G8KHU for this sketch.

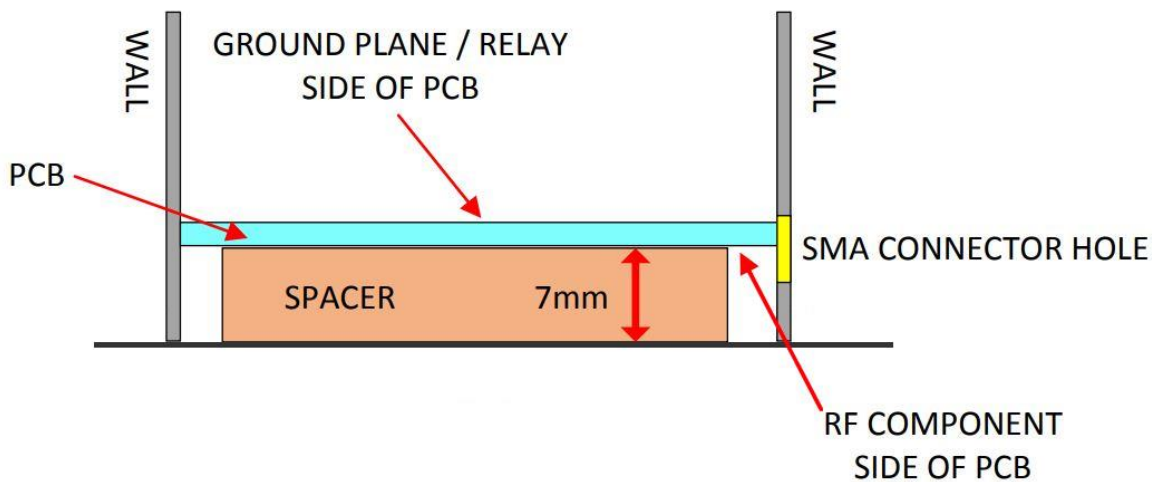

Figure 5 Using a 7mm spacer to fix the PCB in position for soldering to the case

Be aware that if you already soldered some components parts, you need to ensure that your spacer is shaped to avoid the fitted parts.

Drop the spacer into the box so it sits on the inside of lower lid. Use a piece of wood or a plastic block to press the PCB into place against the 7mm spacer. If the PCB is very tight in the box, to the point where it is being distorted, check whether the sharp corners of the board are not allowing the edges to fit against the faces of the box. Remove 0.5 mm of the corner if that is the case. Also check that the 5 x 0.5 mm notches removed from two corners of the PCB are sufficient. You might need to extend them a little to clear then solder fillets on the case seams. Once you are sure that the corners and notches are not causing a problem, but the board still does not fit, check that you haven't overlapped the corner joints of the box too far. Re-solder the joint if necessary or use fine abrasive paper to ease the PCB edges a little until it fits nicely. Hold the PCB in place against the spacer by using a small weight. Apply liquid flux along the edge of the PCB and the inside of the case to help the solder flow.

Solder a few 6mm sections around the edge of the PCB and case using a powerful iron set to around 400C to ensure you get a good fillet. It is best to do this in perhaps 10 places, working on alternate corners/edges so nothing gets distorted by heat. I use 60/40 multicore tin-lead solder and a 4mm chisel bit on a 75W thermostatic iron.

Once you are satisfied that the board is level in the case and at the right spacing, you can fit the lid to the underside with the spacer removed. Seam-solder the rest of the periphery of the board where the ground-plane meets the box sides.

Once the PCB is seam-soldered on the ground-plane face, fit the second lid and turn the box over. Remove the first lid, then clean and apply flux to the places where the board needs soldering to the case on the component side. Take care to leave enough room for R7 and other parts which need to be positioned close to the solder fillet. If either lid is loose, consider adding a tiny dot of solder at the box corners rather than bending the lid to fit. Once complete, inspect everything, then give the board and case a good clean and scrub with IPA or Acetone.

Fitting the components

The circuit diagram and component layout are in [appendix ***** and *****\(NS to add\)](#). I suggest you print that and the board layout, or at least have them available on screen for reference during the build.

Fitting the passives

Now you can continue adding the rest of the SMD components. I do this using a 1mm tip on one 75W iron and a 3mm chisel tip on the other iron. I use a brush to apply liquid rosin flux to the PCB.

I work by putting a tiny spot of tinning on one PCB pad of a component (choose the non-grounded end because earthed pads near vias or the case tend to suck heat away very readily). I position the component with tweezers and hold it in place either with the tweezers or a cocktail stick, applying the 1mm iron at 320C for a second or so until the tinning melts. Then I solder the other pad(s) of the component, finishing with a little reflow for the original pad if it doesn't look perfect under the microscope. For pads near earth vias, I use the iron with the larger bit at 330C.

Start with the remaining inductors, as they are the hardest parts which to get good solder flow and adhesion.

In the kit is an SMD dummy load resistor R7 which can handle about 2 watts average power but fits nicely on the PCB. If your IF rig is likely to produce more than that power, it would be prudent to purchase a replacement resistor, rated for at least 5 watts and providing a good match at UHF. Solder it to the case if possible. My transverters are all set up for IF power of 20 to 50 mW as it seems silly to generate IF power, then dissipate it all in a resistor.

Then fit the remaining fixed resistors and capacitors, *APART FROM R4*. That is fitted after Q3. All of the capacitors are ceramic, so orientation does not matter. It is sometimes suggested that the tiny value porcelain RF caps should be mounted on edge to reduce stray inductance, but I'm not convinced it makes any difference, particularly where the capacitor is narrower than the track.

Where there are several components with one of their ends very close to others on a single pad, I solder the opposite end of each part in turn, then the ends of all parts on the common pad all in a single operation.

Note that R103 is soldered on top of C102 as there is insufficient space in that part of the board.

Making and Fitting L7

Find a piece of *very thin* copper wire (0.2 to 0.3 mm diameter) and make a hairpin 10mm long. Solder that between the pad at the end of C5 and the corner of the track connection to L6.

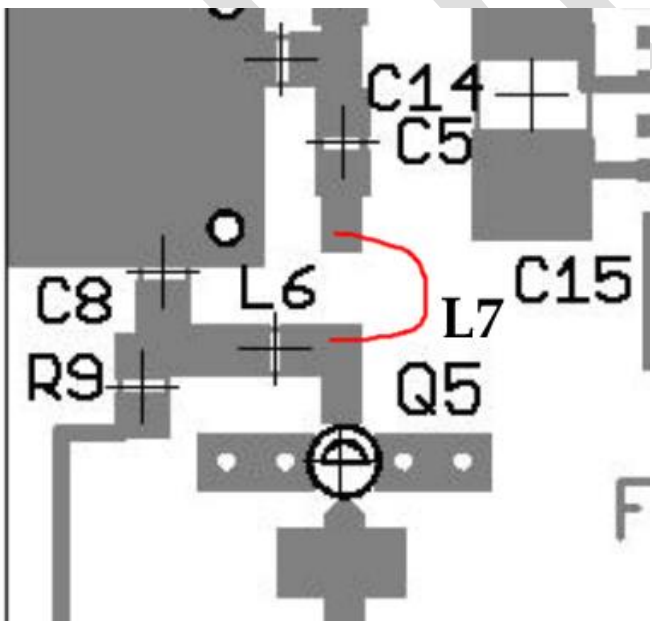

Fitting the variable resistors

Fit the variables, taking care with the orientation and location of R3. Solder any remaining relay pins once all nearby components are fitted. Note that the photo shows a transverter modified for 20-100 mW input power, with a 100R 0805 soldered on top of the 470R R8, although the 56R load resistor should really be replaced with a 68R to maintain a 50 ohm input impedance. Few rigs will care, and certainly the Ukrainian K3 adaptor board I am using as an IF transverter does not care at all. If you prefer, R8 can be replaced with an 82R 0805 resistor, then there is no need to fix the extra “piggy-back” resistor for low power IF drive.



Figure 6 Location of R3 variable between the legs of the relay. Second view is from top left of the first. Red ring shows low power IF modification with 100R fitted over R8

Fitting the relay

I press the relay into place from below and bend over four pins at a 45-degree angle to retain the relay in place, then solder all of the pins. The relay must be aligned such that the stripe is nearest to the LO In end of the PCB. I snip the long ends of the relay pins off, but it isn't vital to do that.

Fitting the sockets and feedthrough caps

Trim the PTFE insulation of the SMA sockets to leave the PTFE flush with the back face of the socket, using a scalpel or craft knife or razor-sharp sidecutters. Try hard not to score or scrape the gold plating on the centre pin. Cut the pin to leave around 3mm of the pin sticking out from the rear of the SMA socket. I file a 30-degree slant on the end of the pins to help control the size of the solder fillet.

Lightly tin the underside of the SMA pin. Clean the back face of the SMA socket and the area around the hole in the outside face of the box using IPA or Acetone, then paint on some liquid flux to the box face and the back of the SMA.

Lightly tin the last 3mm of the PCB track at the PCB edge. I do that by poking the tip of the iron through the hole in the case as it gives much better control. Position the SMA so the centre pin is centred in place above the track, with the mounting holes aligned horizontally so the SMA body can't foul the case lid. Apply the iron to the pin until the solder flows, ensuring that the body is still aligned correctly and in contact with the box face. Check that you don't have any metal whiskers or solder blobs on the insulation or PCB, and that the pin is well clear of the edges of the hole. Now use a large iron at 400C and heat the SMA flange until you see the solder flowing freely. Move the iron and solder around the SMA until there is a nice fillet all round. You'll find

this easiest if you can support the box in a soft clamp or hold it between blocks of wood with the SMA uppermost.

The SMA socket centre pins should be soldered with very small fillets. Note how the slanted filed end of the SMA centre pin helps make a neat fillet.

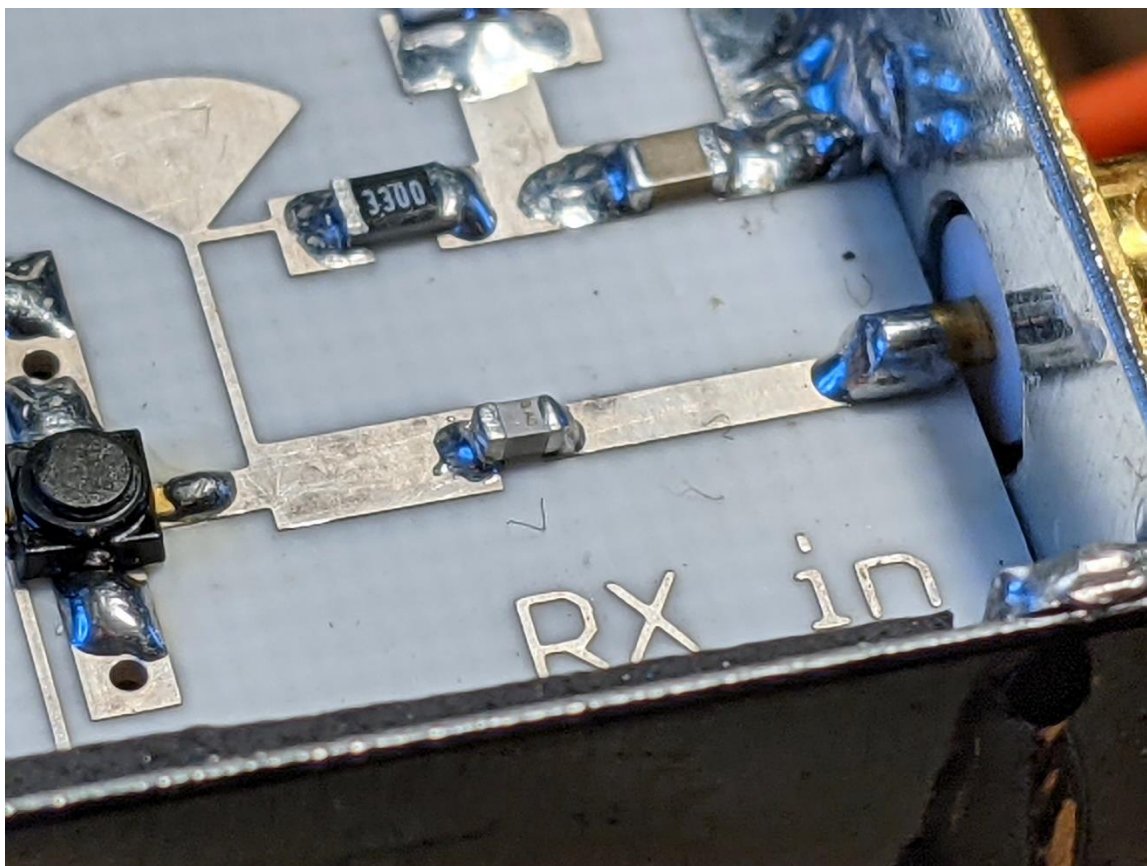

Once all the SMA sockets are trimmed and soldered, solder in the feedthrough caps. Again, it is easiest if the box face with the feedthroughs is horizontal, so they fall naturally into the holes as the solder flows. Try to line up the loops for neatness. Some constructors like to use a ring terminal under each feedthrough to attach ground returns. I just solder the wires to the tinfoil, so I have not included ring terminals in the kits.

If you are using an internal DF9NP board, you don't need to fit the LO input SMA socket, but it might give you additional flexibility later if you want to test other LOs. It would be prudent to fit the 10 MHz reference input SMA as even the TCXO-equipped DF9NP boards can take an external reference with a small modification. When fitting this socket, it doesn't have any PCB to solder the pin to for alignment. If the hole is 4.1 mm and your socket has some 4.06 mm PTFE extending behind its flange, you can leave a couple of mm of the PTFE sleeve in place to fix the socket centrally within the hole. Then you only need to concentrate on aligning parallel to the box edge when soldering. There is enough clearance to allow the use of screws on this socket if you prefer.

Fitting the ICs and DC devices

Take antistatic precautions when handling and soldering the high-side switch Q11. I suggest soldering pin 1 with the dot first, then the four pins on the other side, then pin 4, and finally pins 2 and 3.

Q11 has a pin-1 dot, but also the pin-1 edge of the package has a chamfer, which needs to be furthest from the edge of the board.

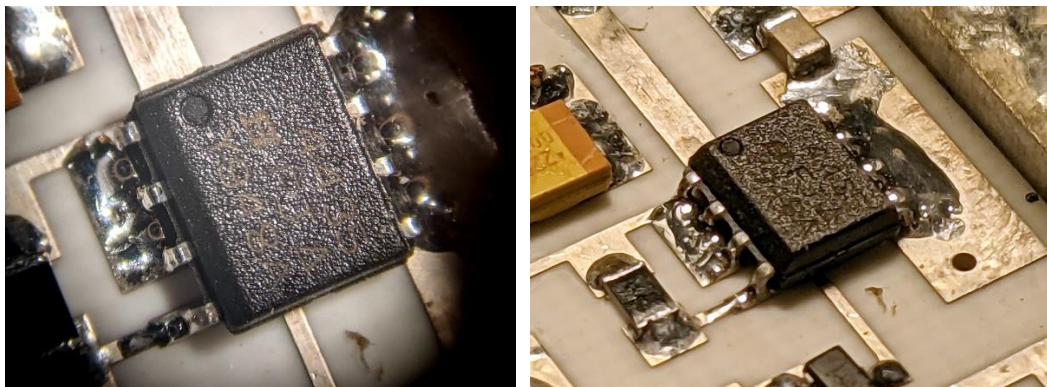
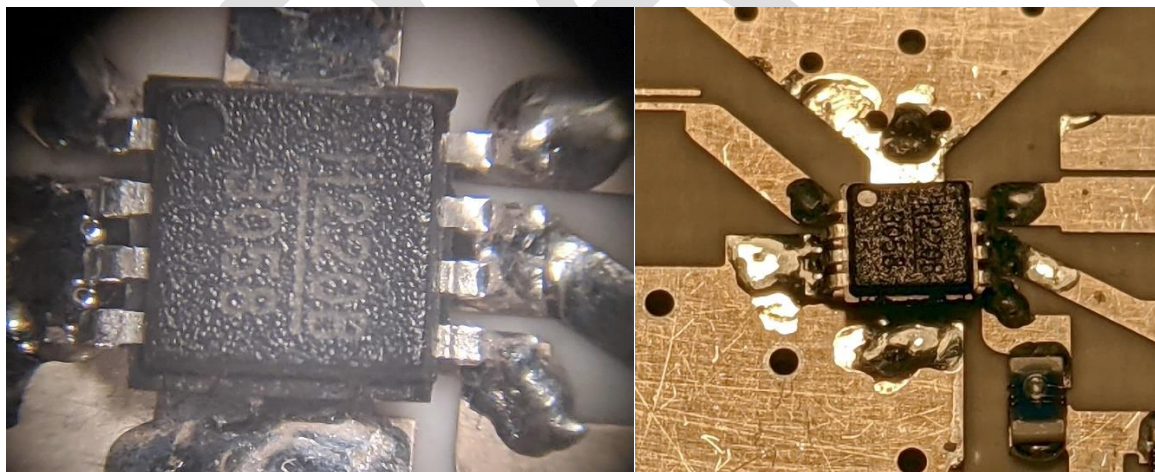

Figure 7 Q11 top and oblique views

Solder in the diode D2, and D3/D4 if not already done.

Fit Q12 and Q3, then R4.

Now you need to make a decision. Some of Michel's earlier instructions suggest omitting the mixer installation until after the local oscillator chain pHEMTs are installed, so that you can measure the power into the mixer, and tweak L7 to achieve an optimal drive. If you have suitable testgear and want to do this, leave the HMC220 installation until later. Otherwise, simply fit the HMC220 mixer Q2 now. Note that it has a pad underneath. Ideally it should be reflowed with paste, but in this application, I find it easiest to put a small blob of solder where the pad is, apply some liquid flux, then place the mixer carefully in place, holding it with tweezers. Apply a soldering iron with a 3-4 mm tip to the ground plane close to the chip until the solder melts, ensuring that the chip seats correctly. Note the orientation of the mixer and take antistatic precautions. (I don't know if the mixer works correctly if the pad is not soldered down, but it is easy enough to do it using this method, so I didn't take the risk)



Fit Q1, IC2, IC3, then taking careful static precautions, fit IC1, the 7660 bias generator.

Note the orientation of IC1. Pin 1 has a dot. That side of the package has a chamfer:

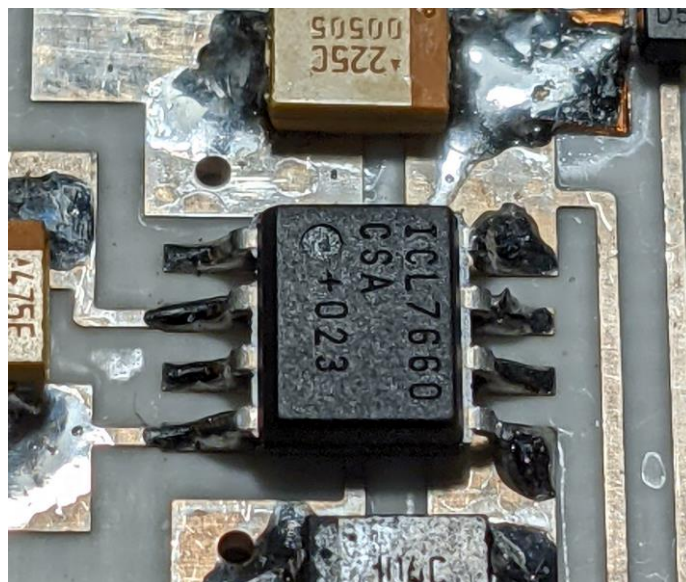

Fitting the wires and coax links

The empty volume on the other side of the board can be used to install a local oscillator board. Please bear that in mind as you are routing the wires and fitting the connections to the feedthrough capacitors.

Before starting, consider fixing the label to the outside of the lid which covers the components. It can save a lot of confusion. If your lids fit any way round, the orientation doesn't matter, but if your lids fit best in a particular direction, make 100% certain that you have the right lid and that it is oriented correctly. Clean both faces of the lid with IPA or Acetone, dry it thoroughly and remove any dust, then peel the vinyl sticker from its backing. Align it very carefully, then rub it gently from the centre outwards, ensuring that there are no air bubbles. Once it is stuck down, rub it all over again to ensure the pressure-sensitive adhesive is firmly stuck.



Turn the lid over and stick the ECCOSORB absorber sheet to the inside, leaving even margins all round. It also has pressure-sensitive adhesive, but please be. Be 100% certain it is in the right place at the first attempt. This stuff is over £10 per piece, and I have no spares. If it does go wrong and the lid won't fit, don't try to unpeel it, just trim off the excess until it fits.

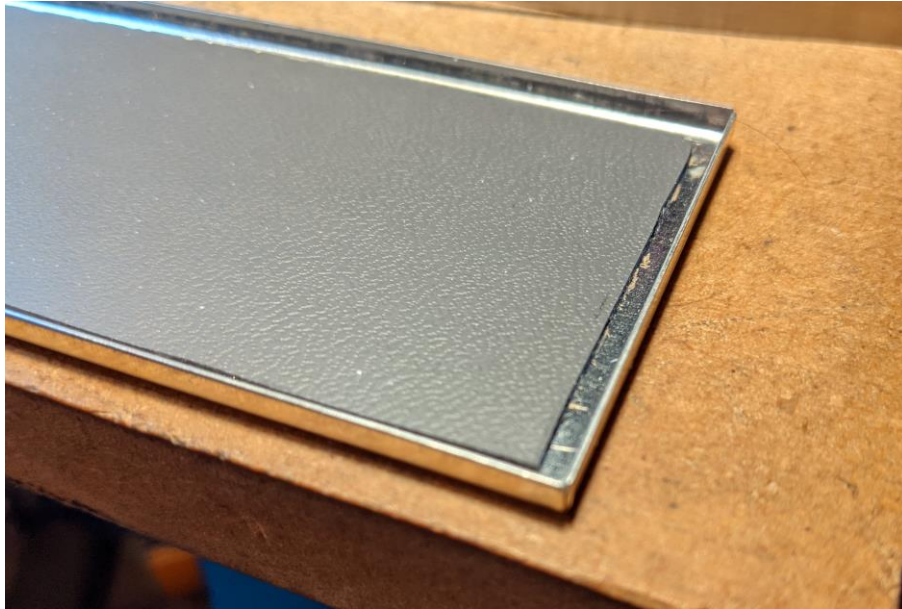

There will be a small extra strip of ECCOSORB in the kit. I find it is sometimes useful to stick a small strip along the edge of the case near the receive front end pHEMT if there is any sign of instability while you are trimming the bias levels for best noise figure. It might also be helpful to fit a little to the LO screening septum.

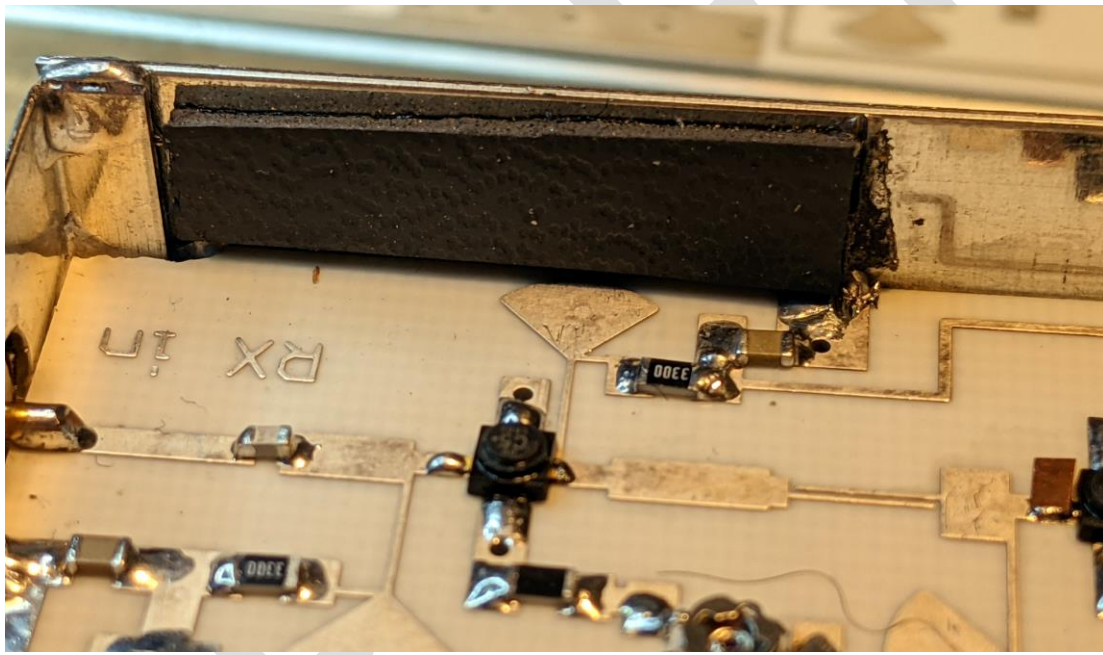

Turn the transverter over and identify the holes for the hook-up wires and the hole you drilled for the PTT resistor (if you are installing PTT). Straighten the wires, then measure and strip each length carefully and solder each of them in place. A small drop of hot-melt glue or high-viscosity superglue might help, but I just bend the ends over on the component side and solder the wires. If you have some 0.085 inch handyform coax, that works really well for the screened wires, and you can solder the screen to the ground plane in a couple of places if you like.

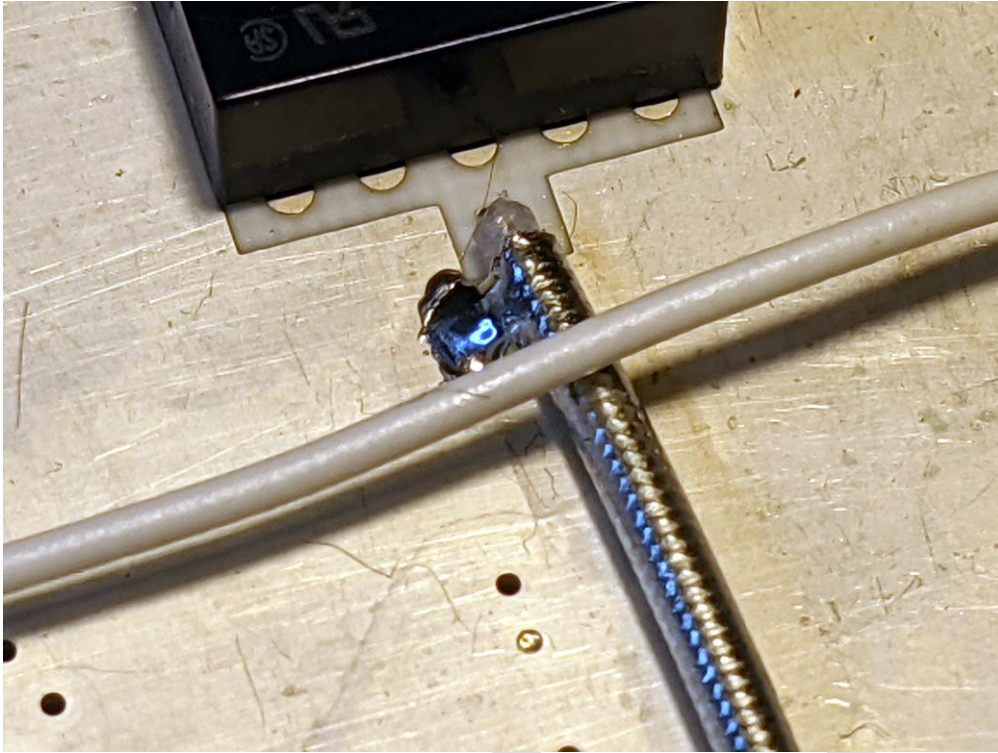

I have included some grey 1.13 mm coax for those connections if you are fresh out of 85 thou handyform. Don't confuse it with the white hookup wire, it really is coax!



Remember to fit the wires leading to the +12 on TX output and fit PTFE or similar 1mm diameter insulation over the wires of the 22k wire-ended resistor and the diode. Make sure the diode is the right way round. Solder the cathode end of the diode (marked with a ring) to the feedthrough and the other to the 22k resistor. Feed the other end of the 22k resistor through the hole you made earlier and solder it to the newly-cut pad. You will need some more of the 0.2mm wire to link from the free end of the resistor to the base of Q101.

If you are using an internal DF9NP local osc board, Michel recommends using screened cable for the long bias wire from the 7660 to the junction of R24, R21, R28 and R30 to help remove synth spurs. .085 handyform or the grey 1.13 mm coax work fine.



Fitting the pHEMTs

Once all parts other than the CE3512K pHEMTs are fitted, connect a +12V supply, preferably current-limited at 1 amp. Check that the receive +5V rail and the -5V from the 7660 are near to those values. The voltage at the other side of the 470R smoothing resistor should be around 4.5 V. Earth the PTT connection (or inject +12V through a 4k7 resistor into the IF port if PTT is not configured). Check that the +5V on transmit is now enabled and near to the correct value and that the supply to the RX 5V rail drops.

Check that you see +12V on the "+12 on TX" output, taking care not to short the output to ground. Set all the TX chain bias pots and LO chain pots to around -0.4V. You may find it easiest to use a cross-point jeweller's screwdriver with the point ground almost flat to operate the open-frame 3 x 3mm pots, but I find a CK T4845 Zirconium Oxide tipped trim tool with a 1.3 mm blade works very well.

Disable PTT and repeat for the RX chain, checking for +5V on each drain pad.

Once you are happy that the DC levels are correct and that TX/RX switching is working correctly, remove the power from the board.

Taking static precautions, tin the drain pads where the pHEMTs Q4 and Q5 will fit. Use a minimum of solder, place each pHEMT so it is aligned centrally between the four pads, hold it down with a cocktail stick and melt the solder on the drain using a fine iron. Try not to spread any solder along the microstrip. Once it is fixed, solder the two source leads using a high-capacity iron, then the gate lead, again using minimal solder. Check the drain connection and reflow with a little more solder if necessary. You may find better results using a dot of solder paste on the gate/drain pads. Michel recommends using a fine iron set to between 320 and 350C to solder the drain and gate tabs, and a hotter iron for the source tables. I use an iron with a larger bit to overcome the loss of heat through the vias to the ground plane, with both set to 320C.

Adjusting the bias of the pHEMTs

OPTIONAL STEP:

*If you decided to omit the HMC220 mixer so you can measure the power into the input port, you will need to solder some **small and very flexible** coaxial cable to the track near the input port and connect that to a power meter or spectrum analyser capable of measuring power at 10 GHz. TAKE EXTREME CARE with the coax connection so you don't damage the PCB tracks. Adjust the size of the wire hairpin L7 and the bias voltages controlled by R14 and R15 to get the best power at the mixer input. Once you are happy with the power at the mixer port, remove the thin coax, clean up any excess solder with de-soldering braid and fit the HMC220 mixer, taking static precautions, working rapidly so as not to degrade the performance of the device.*

Now fit the remaining pHEMTs Q6, 7, 8, 9 and 10.

Michel suggests measuring the voltage across the drain resistors of the pHEMTs, but I find it easier to measure the voltage to ground at the drain side of those resistors. If you have already optimised the LO power in the optional step, there is no need to make any further adjustments to R14 or R15, but I have included them in the table for those who have not done the optional step. These are the updated voltages expected with the CE3512 pHEMTs. It is vital to fit 10GHz-capable dummy loads or long lossy coax leads to the TX and RX ports while making these adjustments, to help avoid oscillation while the case is open. While adjusting the bias, I lay pieces of absorber over the filters and gate connections, as otherwise, the TX and RX chain tend to oscillate strongly until you fit the lid with the ECCOSORB absorber. Adjust the variable resistors to achieve these target voltages with no local oscillator signal and no IF input. You will need to adjust R13 to set a suitable IF drive level for the full power tests.

pHEMT	Pot to adjust	Drain resistor Rn	Voltage at drain end of Rn (no LO/IF)	Voltage at drain end of Rn (with LO and IF at full power on TX)	Voltage across Rn (no LO/IF)	Voltage across Rn (with LO and IF at full power on TX)
Q5	R14	R10	3v4	2v9	1v6	2v1
Q4	R15	R12	3v	2v5	2v	2v5
Q6	R16	R31	3v6	3v35	1v4	1v65
Q7	R17	R32	3v6	2v2	1v4	2v8
Q8	R18	R40	2v		3v	
Q9	R34	R39	3v4		1v6	
Q10	R20	R38	3v4		1v6	

Note that Q5 is listed before Q4 in the table. The “Voltage at drain end of Rn” assumes 5.0V at the supply end of the drain resistors. It is measured from the drain end of the resistor to ground. The orange-shaded columns are measured ACROSS those same resistors.

These are initial settings. You will need to adjust them later to get best TX power/linearity and best RX performance. Optimising the bias of Q6 and Q7 using R16 and R17, and adjusting R13, you should be able to achieve around 10 mW of output power on transmit. If you have a spectrum analyser, you might want to carry out a two-tone test to optimise linearity and control IMDs.

On receive, it should be possible to achieve a conversion gain around 13dB and a noise figure approaching 1dB by adjusting the bias on Q8, 9 and 10 using R18, R34 and R20. It’s important to ensure that the front end is not oscillating - it can be sensitive to what is connected. Use additional pieces of absorber to damp oscillation if necessary, and check with the case lid on to make sure all is well. Oscillation tends to show up as a slightly increased noise level or a loss of sensitivity.

Michel found that fitting a septum across the mixer was very helpful in reducing LO leak-through. I have included a PCB strip in the kit for you to fabricate a septum. You may need to add more screening and perhaps absorbent foam near the septum to get optimal reduction in leak-through. Make sure the septum height is correct, so the lid still fits. Consider whether to cut a slot into the absorber so the top edge of the septum fits into the slot.

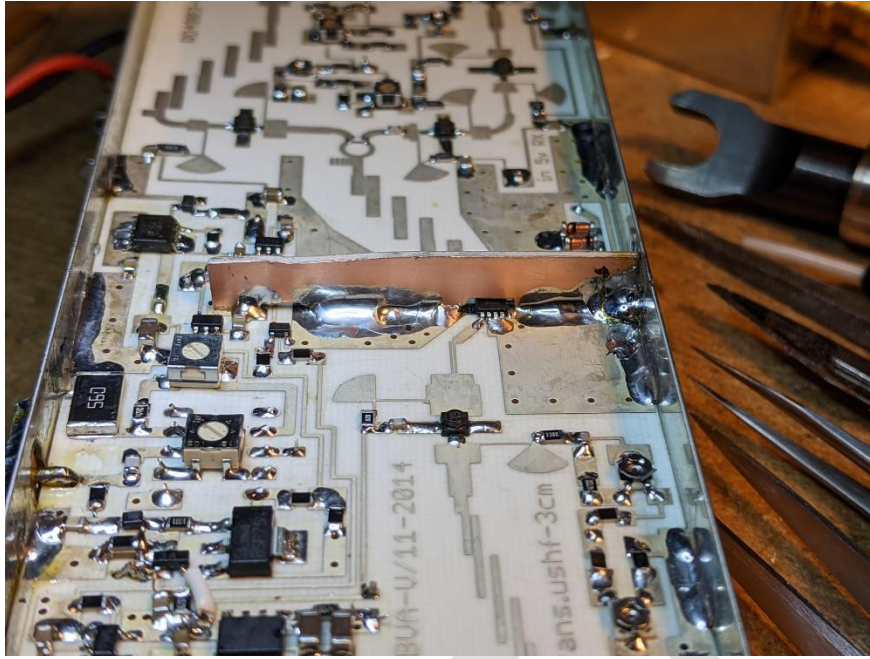

Flaking

The original concept of the transverter design was that it would be used with an LNA, but if you are going to use it barefoot, it is possible to improve the noise figure a little by judicious placement of two copper foil flakes to form tuning stubs.

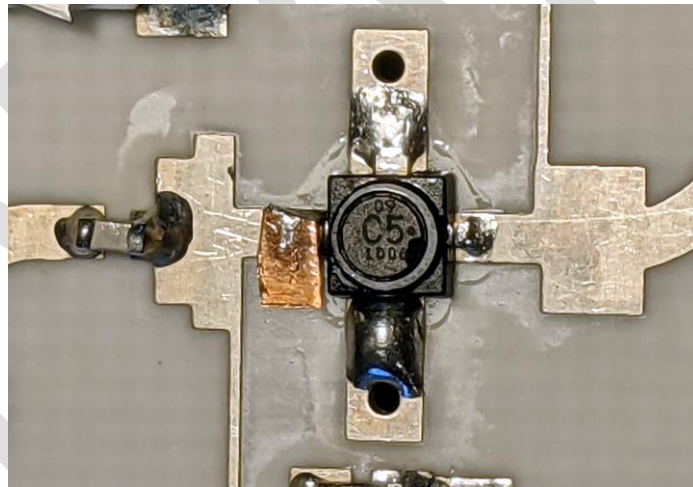

Figure 8 Tuning flake on Q8 drain



Figure 9 Tuning flake on Q9 gate

As Michel says, this is straightforward enough for those who are familiar with the engineering involved, but can be challenging for newcomers to microwaves, especially if you don't have access to suitable test gear. Michel rightly says that the solution is to find a friend who has the right experience and equipment.

A simple calibrated noise source can be used to measure the noise figure of your transverter using a manual technique using an SDR or receiver with a wide IF output and an AC thermal millivoltmeter. The CANFI project is a neat solution to automate the process. http://www.canfi.eu/downloads/mmrt14_CANFI.pdf

It might be useful to run a small group project to assemble, calibrate and distribute suitable noise sources.

DF9NP Local Oscillators

Many members of the Anglophone group purchase project have also purchased a DF9NP local oscillator. These represent excellent value, and while they have much better performance than a basic ADF4351 synth LO, they are not the last word in phase noise performance.

There are frequency-locked high performance crystal oscillator projects which can provide greatly improved noise performance. If you are in an area where there is a high concentration of 10 GHz operators, you may find that reciprocal mixing on receive in the presence of strong local signals will degrade your performance. Also, you may get complaints about phase noise on transmit. In the UK, the small number of active, well-sited 10 GHz stations is small, so the problem is unlikely to arise. There is a discussion of the issues in the document at <https://f6bva.pagesperso-orange.fr/Technique/trans%20uhf%20vers3cm/dossier%20print%20Ag%20complet.pdf>

If you already fitted an SMA for the LO input, consider drilling the case and adding a flying lead with an SMA fitted, or even fitting an SMA output (perhaps a male receptacle?), so you have the flexibility to use the internal LO or an external one.

If you don't need that flexibility and have fitted C40, please remove it now. If the SMA is already fitted, leave it in place, perhaps with a blanking plug. If you missed the step in PCB prep where you drill the hole, please go back to the section "PCB Preparation – Internal LO board".

Connect a coax lead from the DF9NP board output. Use thin coax such as the 1.13 mm coax included in the kit (or .085 handyform semirigid). Solder the braid to the ground plane of the board adjacent to the new hole and

bring the centre conductor through the hole to the component side of the board. Solder the centre conductor to the track where C40 would be fitted (adjacent to L5).

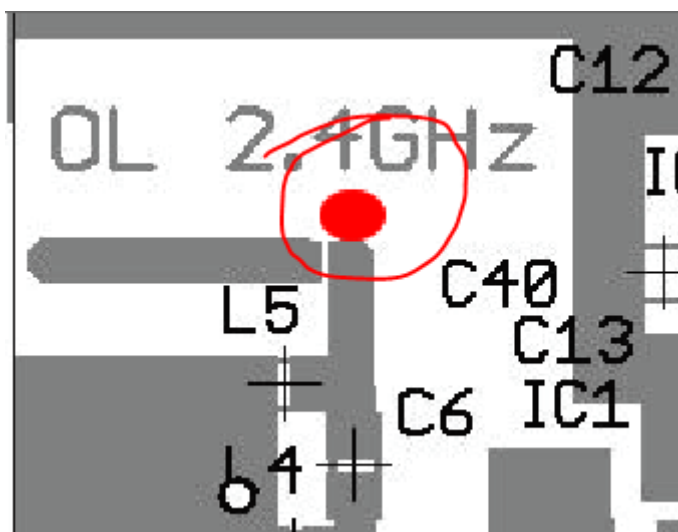

Solder the DF9NP PCB to the tinplate box in the corner above the relay. I use three tacks of solder around 6mm wide in case I need to remove it later. Attach a lead to bring power from the +12V power input feedthrough capacitor.

[Related projects](#)

I am also looking into the possibility of a group buy of parts for a 1-2 watt PA to match this transverter, and perhaps an LNA and a high-performance very low noise locked local oscillator.

Appendices

Appendix A

Box drilling diagram (NS to insert here)

DRAFT

Appendix B: Modified circuit diagram with the optional PTT mods

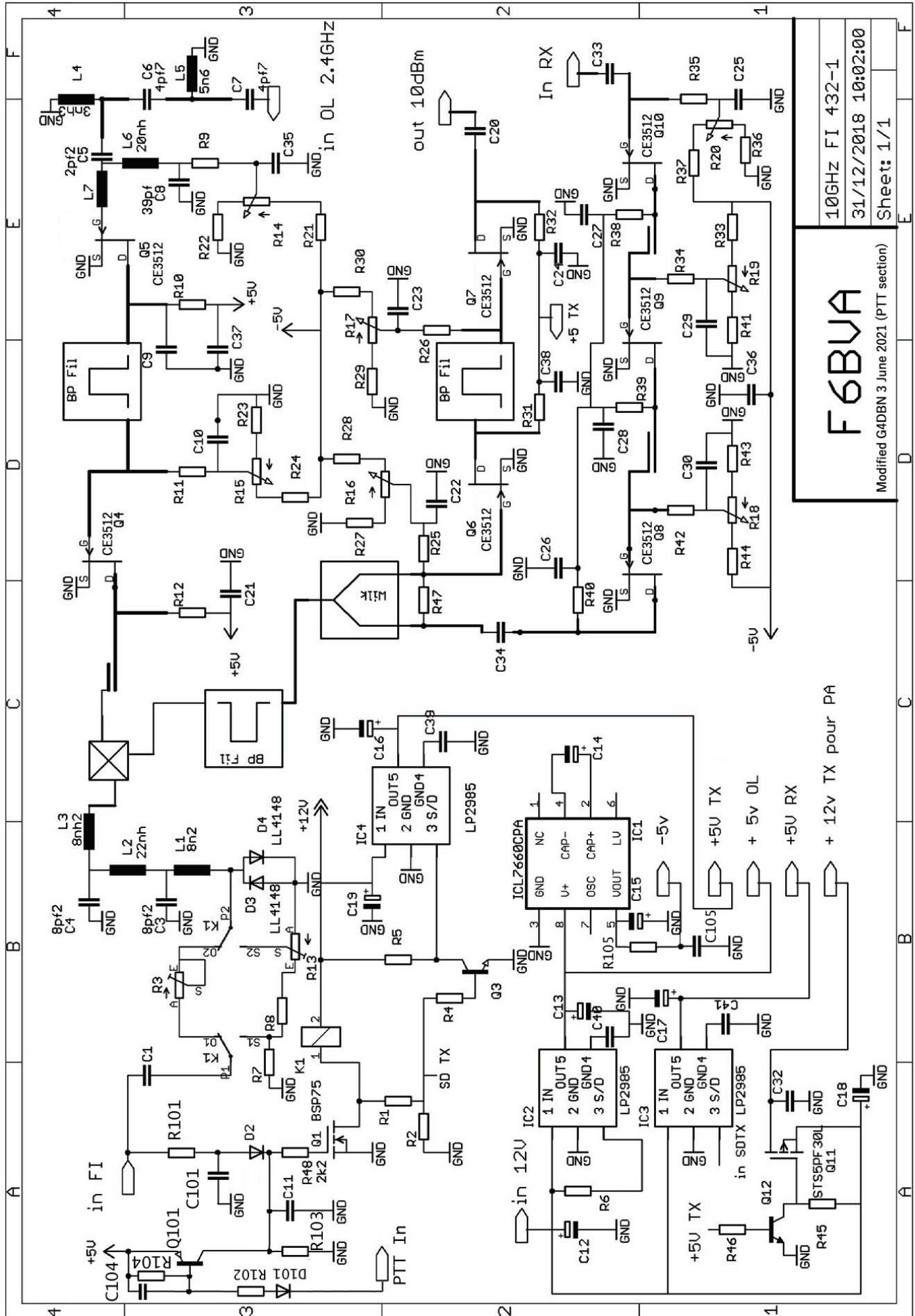

F6BVA

Modified G4DBN 3 June 2021 (PTT section)

10GHZ FI 432-1
31/12/2018 10:02:00
Sheet: 1/1

DRAFT

Appendix D: For reference, here is Michel's original unmodified circuit diagram. There are considerable changes to the area at the upper left corner and a small change around pin 5 of the 7660 bias generator chip.

